

**NIKO<sup>®</sup>**

**NIPPON KODO**  
AUTOMATION TECHNOLOGY



**BALL**



















**BEARINGS**



## **BALL BEARINGS**



<b>TECHNICAL INFORMATION</b>		PAGES FOR REFER
		6 ~ 19
1.	BEARING MATERIALS	6
2.	SHIELDS AND SEALS	6
3.	BEARING TOLERANCES	7 ~ 9
4.	BEARING FITS	9 ~ 10
5.	BEARING INTERNAL CLEARANCE	10 ~ 12
6.	LUBRICATION	12 ~ 14
7.	LOAD RATING AND LIFE	14 ~ 18
8.	BEARING HANDLING	18
9.	ALLOWABLE SPEED	18 ~ 19

<b>PRODUCT INFORMATION</b>		<b>PAGES FOR REFER</b>
		<b>22 ~ 46</b>
	<b>60 SERIES DEEP GROOVE BALL BEARINGS</b>	22 ~ 23
	60., 60..LLB, 60..ZZ	
	<b>62 SERIES DEEP GROOVE BALL BEARINGS</b>	24 ~ 25
	62., 62..LLB, 62..ZZ	
	<b>63 SERIES DEEP GROOVE BALL BEARINGS</b>	26 ~ 27
	63., 63..LLB, 63..ZZ	
	<b>160 SERIES DEEP GROOVE BALL BEARINGS</b>	28
	160..	
	<b>68 SERIES DEEP GROOVE BALL BEARINGS</b>	29 ~ 30
	68., 68..LLB, 68..ZZ	
	<b>69 SERIES DEEP GROOVE BALL BEARINGS</b>	31 ~ 32
	69., 69..LLB, 69..ZZ	
	<b>622 SERIES DEEP GROOVE BALL BEARINGS</b>	33
	622., 622..2RS	
	<b>623 SERIES DEEP GROOVE BALL BEARINGS</b>	34
	623., 623..2RS	
	<b>630 SERIES DEEP GROOVE BALL BEARINGS</b>	35
	630., 630..2RS	
	<b>64 SERIES DEEP GROOVE BALL BEARINGS</b>	36
	64..	
	<b>52 SERIES DOUBLE-ROW ANGULAR CONTACT BALL BEARINGS</b>	37 ~ 38
	52., 52..2RS	
	<b>53 SERIES DOUBLE-ROW ANGULAR CONTACT BALL BEARINGS</b>	39 ~ 40
	53., 53..2RS	
	<b>12 SERIES SELF-ALIGNING BALL BEARINGS</b>	41
	12., 12..K	
	<b>13 SERIES SELF-ALIGNING BALL BEARINGS</b>	42
	13., 13..K	
	<b>22 SERIES SELF-ALIGNING BALL BEARINGS</b>	43 ~ 44
	22., 22..K, 22..2RS	
	<b>23 SERIES SELF-ALIGNING BALL BEARINGS</b>	45 ~ 46
	23., 23..K, 23..2RS	





TECHNICAL TABLES

## 1. Bearing materials

### 1.1 Raceway and rolling element materials

#### 1.1.1 High/mid carbon alloy steel

In general, steel varieties which can be hardened not just on the surface but also deep hardened by the so-called "through hardening method" are used for the raceways and rolling elements of bearings. Foremost among these is high carbon chromium bearing steel, which is widely used.

#### 1.1.2 Mid-carbon chromium steel

Mid-carbon chromium steel incorporating silicon and manganese, which gives it hardening properties comparable to high carbon chromium steel.

### 1.2 Cage materials

Bearing cage materials must have the strength to withstand rotational vibrations and shock loads. These materials must also have a low friction coefficient, be light weight, and be able to withstand bearing operation temperatures.

#### 1.2.1 Pressed cages

For small and medium sized bearings, pressed cages of cold or hot rolled steel with a low carbon content of approx. 0.1% are used. However, depending on the application, austenitic stainless steel is also used.

#### 1.2.2 Plastic cages

Injection molded plastic cages are now widely used: most are made from fiber glass reinforced heat resistant polyamide resin. Plastic cages are light weight, corrosion resistant and have excellent dampening and sliding properties. Heat resistant polyamide resins now enable the production of cages that perform well in applications ranging between  $-40^{\circ}\text{C}$  -  $120^{\circ}\text{C}$ . However, they are not recommended for use at temperatures exceeding  $120^{\circ}\text{C}$ .

## 2. External bearing sealing devices

External seals have two main functions: to prevent lubricating oil from leaking out, and, to prevent dust, water, and other contaminants from entering the bearing. When selecting a seal, the following factors need to be taken into consideration: the type of lubricant (oil or grease), seal peripheral speed, shaft fitting errors, space limitations, seal friction and resultant heat increase, and cost.

Sealing devices for rolling bearings fall into two main classifications: non-contact seals and contact seals.

### 2.1 Non-contact seals:

Non-contact seals utilize a small clearance between the shaft and the housing cover. Therefore friction is negligible, making them suitable for high speed applications. In order to improve sealing capability, clearance spaces are often filled with lubricant.

### 2.2 Contact seals:

Contact seals accomplish their sealing action through the contact pressure of a resilient seal (the lip is often made of synthetic rubber) the sealing surface. Contact seals are generally far superior to noncontact seals in sealing efficiency, although their friction torque and temperature rise coefficients are higher. Furthermore, because the portion of a contact seal rotates while in contact with the shaft, the allowable seal peripheral speed varies depending on seal type.

**3. Ball bearing tolerances**

**3.1 Standard of tolerances**

Ball bearing "tolerances" or dimensional accuracy and running accuracy, are regulated by ISO and JIS standards (rolling bearing tolerances). For dimensional accuracy, these standards prescribe the tolerances necessary when installing bearings on shafts or in housings. Running accuracy is defined as the allowable limits for bearing runout during operation.

**Table 3.1 Comparison of tolerance classifications of national standards**

Standard		Tolerance class				
Japanese industrial standard (JIS)	JIS	class 0,6X	class 6	class 5	class 4	class 2
International Organization for Standardization (ISO)	ISO	Normal class Class 6X	Class 6	Class 5	Class 4	Class 2
Deutsches Institut für Normung (ISO)	DIN	P0	P6	P5	P4	P2
American National Standards Institute (ANSI)	ANSI/ABMA	ABEC-1	ABEC-3	ABEC-5	ABEC-7	ABEC-9

**3.2 Tolerances for radial bearings**

**Table 3.2 Inner rings**

(Unit : μm)

Nominal bore diameter <i>d</i> mm		Single plane mean bore diameter deviation $\Delta d_{mp}$										Single radial plane bore diameter variation $V_{dp}$									
over	incl.	class 0		class 6		class 5		class 4 <sup>Ⓞ</sup>		class 2 <sup>Ⓞ</sup>		diameter series 9					max diameter series 0.1				
		high	low	high	low	high	low	high	low	high	low	high	low	high	low	high	low	high	low	high	low
10	18	0	-8	0	-7	0	-5	0	-4	0	-2.5	10	9	5	4	2.5	8	7	4	3	2.5
18	30	0	-10	0	-8	0	-6	0	-5	0	-2.5	13	10	6	5	2.5	10	8	5	4	2.5
30	50	0	-12	0	-10	0	-8	0	-6	0	-2.5	15	13	8	6	2.5	12	10	6	5	2.5
50	80	0	-15	0	-12	0	-9	0	-7	0	-4.0	19	15	9	7	4.0	19	15	7	5	4.0
80	120	0	-20	0	-15	0	-10	0	-8	0	-5.0	25	19	10	8	5.0	25	19	8	6	5.0

**Table 3.3 Inner rings**

Nominal bore diameter <i>d</i> mm		Single radial plane bore diameter variation $V_{dp}$ max diameter series 2,3,4					Mean single plane bore diameter variation $V_{dmp}$					Inner ring radial runout $K_{ia}$					Face runout with bore $S_d$		
over	incl.	class 0	class 6	class 5	class 4	class 2	class 0	class 6	class 5	class 4	class 2	class 0	class 6	class 5	class 4	class 2	class 5	class 4	class 2
		max.					max.					max.					max.		
10	18	6	5	4	3	2.5	6	5	3	2.0	1.5	10	7	4	2.5	1.5	7.0	3.0	1.5
18	30	8	6	5	4	2.5	8	6	3	2.5	1.5	13	8	4	3.0	2.5	8.0	4.0	1.5
30	50	9	8	6	5	2.5	9	8	4	3.0	1.5	15	10	5	4.0	2.5	8.0	4.0	1.5
50	80	11	9	7	5	4.0	11	9	5	3.5	2.0	20	10	5	4.0	2.5	8.0	5.0	1.5
80	120	15	11	8	6	5.0	15	11	5	4.0	2.5	25	13	6	5.0	2.5	9.0	5.0	2.5



**Table 3.4 Inner rings**

Nominal bore diameter <i>d</i> mm		Inner ring axial runout (with side) <i>S<sub>ia</sub></i> <sup>②</sup> class 5 class 4 class 2			Inner ring width deviation								Inner ring width variation								
					class 0,6				$\Delta B_s$				modified <sup>③</sup> class 0,6 class 5,4				$V_{Bs}$				
									normal class 5,4		class 2						class 0	class 6	class 5 max.	class 4	class 2
over	incl.	high	low	high	low	high	low	high	low	high	low	high	low	high	low	high	low				
10	18	7	3	1.5	0	-120	0	-80	0	-80	0	-250	0	-250	20	20	5	2.5	1.5		
18	30	8	4	2.5	0	-120	0	-120	0	-120	0	-250	0	-250	20	20	5	2.5	1.5		
30	50	8	4	2.5	0	-120	0	-120	0	-120	0	-380	0	-250	20	20	5	3.0	1.5		
50	80	8	5	2.5	0	-150	0	-150	0	-150	0	-380	0	-250	25	25	6	4.0	1.5		
80	120	9	5	2.5	0	-200	0	-200	0	-200	0	-380	0	-380	25	25	7	4.0	2.5		

Note: ① The dimensional difference  $\Delta d_s$  of bore diameter to applied for class 4 and 2 is the same as the tolerance of dimensional difference  $\Delta d_{mp}$  of average bore diameter.

However, the dimensional difference is applied to diameter series 0, 1, 2, 3 and 4 against Class 4, and to all the diameter series against Class 2.

② To be applied for deep groove ball bearing and angular contact ball bearings.

③ To be applied for individual raceway rings manufactured for combined bearing use.

**Table 3.5 Outer rings**

(Unit :  $\mu m$ )

Nominal Outside diameter <i>D</i> mm		Single plane mean outside diameter deviation										Single radial plane outside diameter variation									
		$\Delta D_{mp}$										$V_{Dp}$									
		class 0		class 6		class 5		class 4 <sup>⑥</sup>		class 2 <sup>⑥</sup>		diameter series 9					maxdiameter series 0.1				
over	incl.	high	low	high	low	high	low	high	low	high	low	high	low	high	low	high	low	high	low	high	low
6	18	0	-8	0	-7	0	-5	0	-4	0	-2.5	10	9	5	4	2.5	8	7	4	3	2.5
18	30	0	-9	0	-8	0	-6	0	-5	0	-4.0	12	10	6	5	4.0	9	8	5	4	4.0
30	50	0	-11	0	-9	0	-7	0	-6	0	-4.0	14	11	7	6	4.0	11	9	5	5	4.0
50	80	0	-13	0	-11	0	-9	0	-7	0	-4.0	16	14	9	7	4.0	13	11	7	5	4.0
80	120	0	-15	0	-13	0	-10	0	-8	0	-5.0	19	16	10	8	5.0	19	16	8	6	5.0
120	150	0	-18	0	-15	0	-11	0	-9	0	-5.0	23	19	11	9	5.0	23	19	8	7	5.0
150	180	0	-25	0	-18	0	-13	0	-10	0	-7.0	31	23	13	10	7.0	31	23	10	8	7.0
180	250	0	-30	0	-20	0	-15	0	-11	0	-8.0	38	25	15	11	8.0	38	25	11	8	8.0

**Table 3.6 Outer rings**

Nominal Outside diameter <i>D</i> mm		Single radial plane outside diameter variation					Single radial plane outside diameter variation		Mean single plane outside diameter variation				
		$V_{Dp}$					$V_{Dp}$ <sup>⑥</sup>		$V_{Dmp}$				
		class 0	class 6	class 5	class 4	class 2	2,3,4 class 0	0,1,2,3,4 class 6	class 0	class 6	class 5 max.	class 4	class 2
6	18	6	5	4	3	2.5	10	9	6	5	3	2.0	1.5
18	30	7	6	5	4	4.0	12	10	7	6	3	2.5	2.0
30	50	8	7	5	5	4.0	16	13	8	7	4	3.0	2.0
50	80	10	8	7	5	4.0	20	16	10	8	5	3.5	2.0
80	120	11	10	8	6	5.0	26	20	11	10	5	4.0	2.5
120	150	14	11	8	7	5.0	30	25	14	11	6	5.0	2.5
150	180	19	14	10	8	7.0	38	30	19	14	7	5.0	3.5
180	250	23	15	11	8	8.0	—	—	23	15	8	6.0	4.0

**Table 3.7 Outer rings**

Nominal Outside diameter <i>D</i>		Outer ring radial runout <i>K<sub>ea</sub></i>					Outside surface inclination <i>S<sub>D</sub></i>			Outside ring axial runout <i>S<sub>ea</sub></i> <sup>⑥</sup>			Outer ring width deviation $\Delta C_s$	Outer ring width variation <i>V<sub>cs</sub></i>			
mm		class 0	class 6	class 5 max.	class 4	class 2	class 5	class 4 max.	class 2	class 5	class 4 max.	class 2	all type	class 0,6	class 5	class 4 max.	class 2
over	incl.																
6	18	15	8	5	3	1.5	8	4	1.5	8	5	1.5	Identical to $\Delta B_s$ of inner ring of same bearing	Identical to $\Delta B_s$ and $V_{bs}$ of inner ring of same bearing	5	2.5	1.5
18	30	15	9	6	4	2.5	8	4	1.5	8	5	2.5			5	2.5	1.5
30	50	20	10	7	5	2.5	8	4	1.5	8	5	2.5			5	2.5	1.5
50	80	25	13	8	5	4.0	8	4	1.5	10	5	4.0			6	3.0	1.5
80	120	35	18	10	6	5.0	9	5	2.5	11	6	5.0			8	4.0	2.5
120	150	40	20	11	7	5.0	10	5	2.5	13	7	5.0			8	5.0	2.5
150	180	45	23	13	8	5.0	10	5	2.5	14	8	5.0			8	5.0	2.5
180	250	50	25	15	10	7.0	11	7	4.0	15	10	7.0			10	7.0	4.0

Note: ⑤ The dimensional difference  $\Delta D_s$  of outer diameter to be applied for classes 4 and 2 is the same as the tolerance of dimensional difference  $\Delta D_{mp}$  of average outer diameter. However, the dimensional difference is applied to diameter series 0,1,2,3 and 4 against Class 4, and also to all the diameter series against Class 2.  
 ⑥ To be applied in case snap rings are not installed on the bearings.  
 ⑦ To be applied for Deep Groove Ball Bearings and Angular Contact Ball Bearings.

**4. Bearing fits**

**4.1 Interference**

For rolling bearings, inner and outer rings are fixed on the shaft or in the housing so that relative movement does not occur between fitted surfaces during operation or under load. This relative movement (referred to as "creep") between the fitted surfaces of the bearing and the shaft or housing can occur in a radial direction, an axial direction, or in the direction of rotation. To help prevent this creeping movement, bearing rings and the shaft or housing are installed with one of three interference fits, a "tight fit" (also called shrink fit), "transition fit," or "loose fit" (also called clearance fit), and the degree of interference between their fitted surfaces varies.

The most effective way to fix the fitted surfaces between a bearing's raceway and shaft or housing is to apply a "tight fit." The advantage of this tight fit for thin walled bearings is that it provides uniform load support over the entire ring circumference without any loss of load carrying capacity. However, with a tight fit, ease of installation and disassembly is lost; And when using a non-separable bearing as the floating-side bearing, axial displacement is not possible. For this reason, a tight fit cannot be recommended in all cases.

**4.2 The necessity of a proper fit**

In some cases, improper fit may lead to damage and shorten bearing life, therefore it is necessary to make a careful analysis in selecting a proper fit. Some of the negative conditions caused by improper fit are listed below.

- Raceway cracking, early peeling and displacement of raceway
- Raceway and shaft or housing abrasion caused by creeping and fretting corrosion
- Seizing caused by loss of internal clearances
- Increased noise and lowered rotational accuracy due to raceway groove deformation

4.3 Fit selection

Selection of a proper fit is dependent upon thorough analysis of bearing operating conditions, including consideration of:

- Shaft and housing material, wall thickness, finished surface accuracy, etc.
- Machinery operating conditions ( nature and magnitude of load, rotational speed, temperature, etc.)



4.3.1 "Tight fit," "transition fit," or "loose fit"

For raceways under rotating loads, a tight fit is necessary. (Refer to Table 4.1) "Raceways under rotating loads" refers to raceways receiving loads rotating relative to their radial direction. For raceways under static loads, on the other hand, a loose fit is sufficient.

(Example) Rotating inner ring load the direction of the radial load on the inner ring is rotating relatively.

For non-separable bearings, such as Deep Groove Ball Bearings, it is generally recommended that either the inner ring or outer ring be given a loose fit.

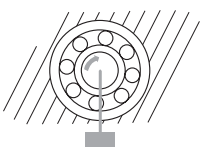
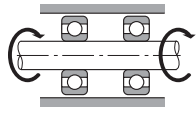
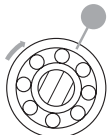
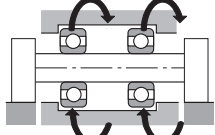
**Table 4.1 Radial load and bearing**

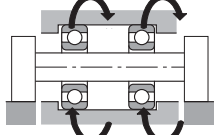
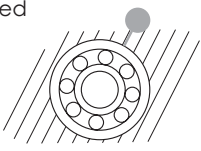
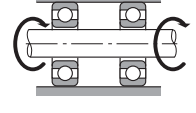
Illustration	Bearing rotation	Ring load	Fit
<p>Static load</p> 	 <p>Inner ring: Rotating Outer ring: Stationary</p>	Rotating inner ring load	Inner ring: Tight fit
<p>Unbalanced load</p> 	 <p>Inner ring: Stationary Outer ring: Rotating</p>	Static outer ring load	Outer ring: Loose fit
<p>Static load</p> 	 <p>Inner ring: Stationary Outer ring: Rotating</p>	Static inner ring load	Inner ring: Loose fit
<p>Unbalanced load</p> 	 <p>Inner ring: Rotating Outer ring: Stationary</p>	Rotating outer ring load	Outer ring: Tight fit

**5. Ball bearing internal clearance**

Ball bearing internal clearance (initial clearance) is the amount of internal clearance a bearing has before being installed on a shaft or in a housing. The internal clearance values for **NIKO** ball bearing classes are shown in tables 5.1 to 5.5

**Table 5.1 Radial internal clearance of Deep Groove Ball Bearings (Unit : μm)**

Nominal bore diameter d (mm)		C2		CN		C3		C4		C5	
over	incl.	min.	max.	min.	max.	min.	max.	min.	max.	min.	max.
6	10	0	7	2	13	8	23	14	29	20	37
10	18	0	9	3	18	11	25	18	33	25	45
18	24	0	10	5	20	13	28	20	36	28	48
24	30	1	11	5	20	13	28	23	41	30	53
30	40	1	11	6	20	15	33	28	46	40	64
40	50	1	11	6	23	18	36	30	51	45	73
50	65	1	15	8	28	23	43	38	61	55	90
65	80	1	15	10	30	25	51	46	71	65	105
80	100	1	18	12	36	30	58	53	84	75	120
100	120	2	20	15	41	36	66	61	97	90	140

**Table 5.2 Radial internal clearance for Self-aligning Ball Bearings (for bearing with cylindrical bore) (Unit : μm)**

Nominal bore diameter d (mm)		Bearing with cylindrical bore							
over	incl.	C2		Normal		C3		C4	
		min.	max.	min.	max.	min.	max.	min.	max.
6	10	2	9	6	17	12	25	19	33
10	14	2	10	6	19	13	26	21	35
14	18	3	12	8	21	15	28	23	37
18	24	4	14	10	23	17	30	25	39
24	30	5	16	11	24	19	35	29	46
30	40	6	18	13	29	23	40	34	53
40	50	6	19	14	31	25	44	37	57
50	65	7	21	16	36	30	50	45	69
65	80	8	24	18	40	35	60	54	83

**Table 5.3 Radial internal clearance for Self-aligning Ball Bearings (for bearing with tapered bore) (Unit : μm)**

Nominal bore diameter		Bearing with tapered bore							
d (mm)		C2		Normal		C3		C4	
over	incl.	min.	max.	min.	max.	min.	max.	min.	max.
6	10	—	—	—	—	—	—	—	—
10	14	—	—	—	—	—	—	—	—
14	18	—	—	—	—	—	—	—	—
18	24	7	17	13	26	20	33	28	42
24	30	9	20	15	28	23	39	33	50
30	40	12	24	19	35	29	46	40	59
40	50	14	27	22	39	33	52	45	65
50	65	18	32	27	47	41	61	56	80
65	80	23	39	35	57	50	75	69	98

**Table 5.4 Radial internal clearance of double row Angular Contact Ball Bearings (Unit : μm)**

Nominal bore diameter		C2		Normal		C3		C4	
d (mm)		min.	max.	min.	max.	min.	max.	min.	max.
over	incl.								
-	10	6	12	8	15	15	22	22	30
10	18	6	12	8	15	15	24	30	40
18	30	6	12	10	20	20	32	40	55
30	50	8	14	14	25	25	40	55	75

**Table 5.5 Radial internal clearance of bearings for electric motor**

(Unit : μm)

Nominal bore diameter		Radial internal clearance CM	
d (mm)		Deep groove ball bearings	
over	incl.	min.	max.
10(incl.)	18	4	11
18	24	5	12
24	30	5	12
30	40	9	17
40	50	9	17
50	65	12	22
65	80	12	22

**6. Lubrication**

**6.1 Lubrication of rolling bearings**

The purpose of bearing lubrication is to prevent direct metallic contact between the various rolling and sliding elements. This is accomplished through the formation of a thin oil (or grease) film on the contact surfaces. However, for rolling bearings, lubrication has the following advantages:

- (1) Friction and wear reduction
- (2) Friction heat dissipation
- (3) Prolonged bearing life
- (4) Prevention of rust
- (5) Protection against harmful elements

In order to achieve the above effects, the most effective lubrication method for the operating conditions must be selected. Also a good quality, reliable lubricant must be selected. In addition, an effectively designed sealing system that prevents the intrusion of damaging elements ( dust, water, etc. ) into the bearing interior, removes other impurities from the lubricant, and prevents lubricant from leaking to the outside, is also a requirement.

Almost all rolling bearings use either grease or oil lubrication methods, but in some special applicatic solid lubricant such as molybdenum disulfide or graphite may be used.

6.2 Grease lubrication

Grease type lubricants are relatively easy to handle require only the simplest sealing devices for these reasons, grease is the most widely used lubricant rolling bearings.

6.2.1 Types and characteristics of grease

Lubricating grease are composed of either a mineral base or a synthetic oil base. To this base a thicks other additives are added. The properties of all greases are mainly determined by the kind of base oil use the combination of thickening agent and various additives.

Standard greases and their characteristics are Table 6.2. As performance characteristics of even same type of grease will vary widely from brand, it is best to check the manufacturers' data when selecting a grease.

**Table 6.1 Grease varieties and characteristics**

Grease name	Lithium grease			Sodium grease (Fiber grease)	Calcium compound base grease
Thickener	Li soap			Na soap	Ca+Na soap Ca+Li soap
Base oil	Mineral oil	Diester oil	Silicone oil	Mineral oil	Mineral oil
Dropping poin °C	170 ~ 190	170 ~ 190	200 ~ 250	150 ~ 180	150 ~ 180
Operating temperature range °C	-30 ~ +130	-50 ~ +130	-50 ~ +160	-20 ~ +130	-20 ~ +120
Mechanical stability	Excellent	Good	Good	Excellent ~ Good	Excellent ~ Good
Pressure resistance	Good	Good	poor	Good	Excellent ~ Good
Water resistance	Good	Good	Good	Good ~ poor	Good ~ poor
Applications	Widest range of applications. Grease used in all types of rolling bearings.	Excellent low temperature and wear characteristics. Suitable for small sized and miniature bearings.	Suitable for high and low temperatures. Unsuitable for heavy load applications due to low oil film strength.	Some emulsification when water is introduced. Excellent characteristics at relatively high temperatures.	Excellent pressure resistance and mechanical stability. Suitable for bearings receiving shock loads.

Grease name	Aluminum grease	Non-soap base grease	
		Thickener	
Thickener	Al soap	Bentone, silica gel, urea, carbon black, fluorine compounds, etc.	
Base oil	Mineral oil	Mineral oil	Synthetic oil
Dropping point °C	70 ~ 90	250 or above	250 or above
Operating temperature range °C	-10 ~ +80	-10 ~ +130	-50 ~ +200
Mechanical stability	Good ~ poor	Good	Good
Pressure resistance	Good	Good	Good
Water resistance	Good	Good	Good
Applications	Excellent viscosity characteristics. Suitable for bearings subjected to vibrations.	Can be used in a wide range of low to high temperatures. Shows excellent heat resistance, cold resistance, chemical resistance, and other characteristics when matched with a suitable base oil and thickener.  Grease used in all types of rolling bearings.	

**7. Load rating and life**

**7.1 Bearing life**

Even in bearings operating under normal conditions, the surfaces of the raceway and rolling elements are constantly being subjected to repeated compressive stresses which causes flaking of these surfaces to occur. This flaking is due to material fatigue and will eventually cause the bearings to fail. The effective life of a bearing is usually defined in terms of the total number of revolutions a bearing can undergo before flaking of either the raceway surface or the rolling element surfaces occurs.

Other causes of bearing failure are often attributed to problems such as seizing, abrasions, cracking, chipping, gnawing, rust, etc. However, these so called "causes" of bearing failure are usually themselves caused by improper installation, insufficient or improper lubrication, faulty sealing or inaccurate bearing selection. Since the above mentioned "causes" of bearing failure can be avoided by taking the proper precautions, and are not simply caused by material fatigue, they are considered separately from the flaking aspect.

**7.2 Basic rating life and basic dynamic load rating**

A group of seemingly identical bearings when subjected to identical load and operating conditions will exhibit a wide diversity in their durability.

This "life" disparity can be accounted for by the difference in the fatigue of the bearing material itself. This disparity is considered statistically when calculating bearing life, and the basic rating life is defined as follows.

The basic rating life is based on a 90% statistical model which is expressed as the total number of revolutions 90% of the bearings in an identical group of bearings subjected to identical operating conditions will attain or surpass before flaking due to material fatigue occurs. For bearings operating at fixed constant speeds, the basic rating life (90% reliability) is expressed in the total number of hours of operation.

The basic dynamic load rating is an expression of the load capacity of a bearing based on a constant load which the bearing can sustain for one million revolutions (the basic life rating). For radial bearings this rating applies to pure radial loads, and for thrust bearings it refers to pure axial loads. The basic dynamic load ratings given in the bearing tables of this catalog are for bearings constructed of **NIKO** standard bearing materials, using standard manufacturing techniques. Please consult **NIKO** engineering for basic load ratings of bearings constructed of special materials or using special manufacturing techniques.

The relationship between the basic rating life, the basic dynamic load rating and the bearing load is given in formula (7.1).

$$L_{10} = \left(\frac{C}{P}\right)^P \dots\dots\dots(7.1)$$

where,

$P = 3$  ..... For ball bearings

$L_{10}$  : Basic rating life 10<sup>6</sup> revolutions

$C$  : Basic dynamic rating load,  $n$   
( $C_r$ : radial bearings)

$P$  : Equivalent dynamic load,  $n$   
( $P_r$ : radial bearings)

The basic rating life can also be expressed in terms of hours of operation (revolution), and is calculated as shown in formula (7.2).

$$L_{10h} = 500 f_h n^p \dots\dots\dots(7.2)$$

$$f_h = f_n \frac{C}{P} \dots\dots\dots(7.3)$$

$$f_n = \left(\frac{33.3}{n}\right)^{1/p} \dots\dots\dots(7.4)$$

where,

$L_{10h}$  : Basic rating life,  $h$

$f_h$  : Life factor

$f_n$  : Speed factor

$n$  : Rotational speed, r/min

Formula (7.2) can also be expressed as shown in formula (7.5).

$$L_{10h} = \frac{10^6}{60n} \left(\frac{C}{P}\right)^P \dots\dots\dots(7.5)$$

The relationship between rotational speed  $n$  and speed factor  $f_n$  as well as the relation between the basic rating life  $L_{10h}$  and the life factor  $f_n$  is shown in Fig. 7.1. When several bearings are incorporated in machines or equipment as complete units, all the bearings in the unit are considered as a whole when computing bearing life (see formula 7.6). The total bearing life of the unit is a life rating based on the viable lifetime of the unit before even one of the bearings fails due to rolling contact fatigue.

$$L = \frac{1}{\left(\frac{1}{L_1^e} + \frac{1}{L_2^e} + \dots + \frac{1}{L_n^e}\right)^{1/e}} \dots\dots\dots(7.6)$$

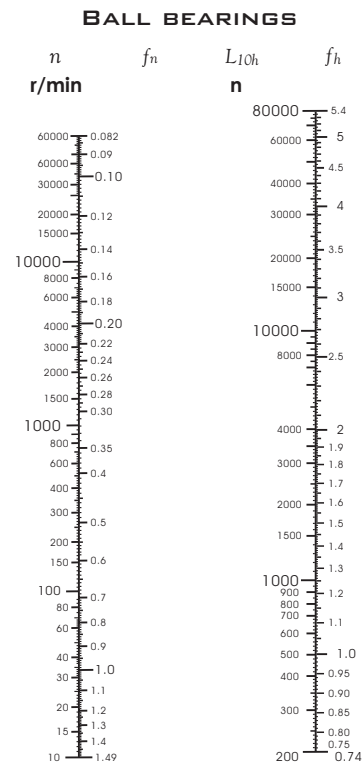

**FIG.7.1 BEARING LIFE RATING SCALE**



where,

$e = 10/9$ .....For ball bearings

$L =$  Total basic rating life or entire unit,  $h$

$L_1, L_2...L_n$  : Basic rating life or individual bearings, 1, 2,... $n$ ,  $h$

When the load conditions vary at regular intervals, the life can be given by formula (7.7).

$$L_m = (\sum \phi_j / L_j)^{-1} \dots\dots\dots(7.7)$$

where,

$\phi_j$  : Frequency of individual load conditions

$L_j$  : Life under individual conditions

**7.3 Machine applications and requisite life**

When selecting a bearing, it is essential that the requisite life of the bearing be established in relation to the operating conditions. The requisite life of the bearing is usually determined by the type of machine in which the bearing will be used, and duration of service and operational reliability requirements. When determining bearing size, the fatigue life of the bearing is an important factor; however, besides bearing life, the strength and rigidity of the shaft and housing must also be taken into consideration.

**7.4 Adjusted life rating factor**

The basic bearing life rating (90% reliability factor) can be calculated through the formulas mentioned earlier in Section 7.2. However, in some applications a bearing life factor of over 90% reliability may be required. To meet these requirements, bearing life can be lengthened by the use of specially improved bearing materials or special construction techniques. Moreover, according to elastohydrodynamic lubrication theory, it is clear that the bearing operating conditions (lubrication, temperature, speed, etc.) all exert an effect on bearing life. All these adjustment factors are taken into consideration when calculating bearing life, the adjusted bearing life can be determined.

$$L_{na} = a_1 \cdot a_2 \cdot a_3 \cdot (C/P)^P \dots\dots\dots(7.8)$$

where,

$L_{na}$  : Adjusted life rating in millions of revolutions ( $10^6$ )(adjusted for reliability, material and operating conditions)

$a_1$  : Reliability adjustment factor

$a_2$  : Material adjustment factor

$a_3$  : Operating condition adjustment factor

**7.4.1 Life adjustment factor for reliability  $a_1$**

The values for the reliability adjustment factor  $a_i$  (for a reliability factor higher than 90%) can be found in Table 7.1

**Table 7.1 Reliability adjustment factor values  $a_1$**

Reliability %	$L_n$	Reliability factor $a_1$
90	$L_{10}$	1.00
95	$L_5$	0.62
96	$L_4$	0.53
97	$L_3$	0.44
98	$L_2$	0.33
99	$L_1$	0.21

**7.4.2 Life adjustment factor for material  $a_2$**

The life of a bearing is affected by the material type and quality as well as the manufacturing process. In this regard, the life is adjusted by the use of an  $a_2$  factor.

The basic dynamic load ratings listed in the catalog are based on **NIKO's** standard material and process, therefore, the adjustment factor  $a_2 = 1$ . When special materials or processes are used the adjustment factor can be larger than 1.

**NIKO** bearings can generally be used up to 120°C. If bearings are operated at a higher temperature, the bearing must be specially heat treated (stabilized) so that inadmissible dimensional change does not occur due to changes in the micro-structure. This special heat treatment might cause the reduction of bearing life because of a hardness change.

**7.4.3 Life adjustment factor  $a_3$  for operating conditions**

The operating conditions life adjustment factor  $a_3$  is used to adjust for such conditions as lubrication, operating temperature, and other operation factors which have an effect on bearing life.

Generally speaking, when lubricating conditions are satisfactory, the  $a_3$  factor has a value of one; and when lubricating conditions are exceptionally favorable, and all other operating conditions are normal, as can have a value greater than one.

However, when lubricating conditions are particularly unfavorable and the oil film formation on the contact surfaces of the raceway and rolling elements is insufficient, the value of  $a_3$  becomes less than one. This insufficient oil film formation can be caused, for example, by the lubricating oil viscosity being too low for the operating temperature (below 13 mm<sup>2</sup>/s for ball bearings or by exceptionally low rotational speed (nr/min x dpmm less than 10,000). For bearings used under special operating conditions, please consult **NIKO** engineering.

As the operating temperature of the bearing increases, the hardness of the bearing material decreases. Thus, the bearing life correspondingly decreases. The operating temperature adjustment values are shown in Fig.7.2.

**7.5 Basic static load rating**

When stationary rolling bearings are subjected to static loads, they suffer from partial permanent deformation of the contact surfaces at the contact point between the rolling elements and the raceway. The amount of deformity increases as the load increases, and if this increase in load exceeds certain limits, the subsequent smooth operation of the bearings is impaired.

It has been found through experience that a permanent deformity of 0.0001 times the diameter of the rolling element, occurring at the most heavily stressed contact point between the raceway and the rolling elements, can be tolerated without any impairment in running efficiency.

The basic rating static load refers to a fixed static load limit at which a specified amount of permanent deformation occurs. It applies to pure radial loads for radial bearings and to pure axial loads for thrust bearings. The maximum applied load values for contact stress occurring at the rolling element and raceway contact points are given below.

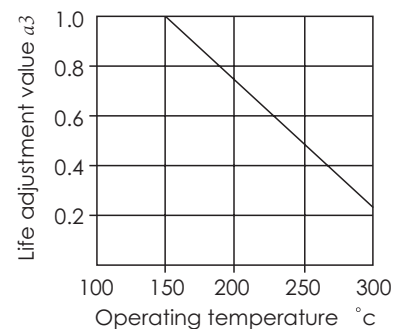

**Fig. 7.2 Life adjustment value for operating temperature**

For ball bearings 4,200 Mpa  
 (except Self-aligning Ball Bearings)  
 For Self-aligning Ball Bearings 4,600 Mpa

**7.6 Allowable static equivalent load**

Generally the static equivalent load which can be permitted is limited by the basic static load rating. However, depending on requirements regarding friction and smooth operation, these limits may be greater or lesser than the basic static rating load. In the following formula (3.9) and Table 7.3 the safety factor  $S_o$  can be determined considering the maximum static equivalent load.

$$S_o = C_o/P_o \dots\dots\dots (3.9)$$

where,

$S_o$  : Safety factor

$C_o$  : Basic static rating load, N (radial bearings:  $C_{or}$ )

$P_o \text{ max}$  : Maximum static equivalent load, N (radial:  $P_{or \text{ max}}$ )

**Table 7.3 Minimum safety factor values  $S_o$**

Operating conditions	Ball Bearings
High rotational accuracy demand	2
Normal rotating accuracy demand (Universal application)	1
Slight rotational accuracy deterioration permitted (Low speed, heavy loading, etc.)	0.5

**8. Bearing handling**

**Bearing storage**

Most rolling bearings are coated with a rust preventative before being packed and shipped, and they should be stored at room temperature with a relative humidity of less than 60%.

**9. Allowable speed**

As bearing speed increases, the temperature of the bearing also increases due to friction heat generated in the bearing interior. If the temperature continues to rise and exceeds certain limits, the efficiency of the lubricant starts to fail down drastically, and the bearing can no longer continue to operate in a stable manner. Therefore, the maximum speed at which it is possible for the bearing to continuously operate without the generation of excessive heat beyond specified limits, is called the allowable speed (r/min). The allowable speed of a bearing depends on the type of bearing, bearing dimensions, type of cage, load, lubricating conditions, and cooling conditions.

The allowable speeds listed in the bearing tables for grease and oil lubrication are for standard **NIKO** bearings under normal operating conditions, correctly installed, using the suitable lubricants with adequate supply and proper maintenance. Moreover, these values are based on normal load conditions ( $P \leq 0.09C$ ,  $F_a/F_r \leq 0.3$ ). For ball bearings with contact seals (LLU type), the allowable speed is determined by the peripheral lip speed of the seal.

For bearings to be used under heavier than normal load conditions, the allowable speed values listed in the bearing tables must be multiplied by an adjustment factor. The adjustment factors  $f_L$  and  $f_C$  are given in Figs. 9.1 and 9.2.

Also, when radial bearings are mounted on vertical shafts, lubricant retentions and cage guidance are not favorable compared to horizontal shaft mounting.

Therefore, the allowable speed should be reduced to approximately 80% of the listed speed.

It is possible to operate precision bearings with high speed specification cages at speeds higher than those listed in the bearing tables, if special precautions are taken. These precautions should include the use of forced oil circulation methods such as oil jet or oil mist lubrication.

Under such high speed operating conditions, when special care is taken, the standard allowable speeds given in the bearing tables can be adjusted upward. The maximum speed adjustment values,  $f_B$ , by which the bearing table speeds can be multiplied, are shown in Table 9.1. However, for any application requiring speeds in excess of the standard allowable speed, please consult **NIKO** Engineering.

**Fig.9.1 Value of adjustment factor  $f_L$  depends on bearing load**

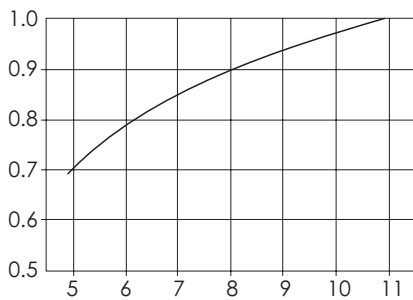

**Fig.9.2 Value of adjustment factor  $f_C$  depends on combined load**

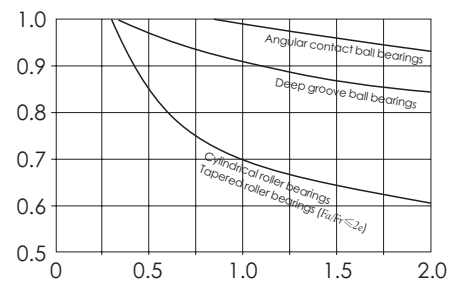

**Table 9.1 Adjustment factor,  $f_B$ , for allowable number of revolutions**

Type of bearing	Adjustment factor $f_B$
Deep groove ball bearings	3.0
Angular contact ball bearings	2.0





**DIMENSION TABLES**

**BALL BEARING**  
**SERIES 60**

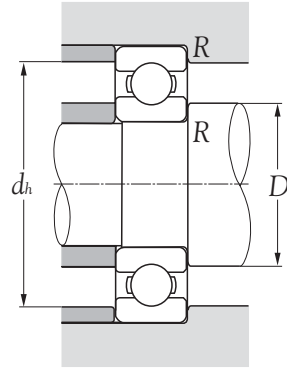
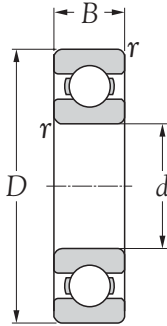

Boundary dimensions mm				Basic load ratings dynamic static N		Limiting speeds rpm		Bearing numbers	Abutment and fillet dimensions mm			Mass kg (approx.)
<i>d</i>	<i>D</i>	<i>B</i>	<i>r<sub>s min</sub><sup>1)</sup></i>	<i>C<sub>r</sub></i>	<i>C<sub>or</sub></i>	grease	oil		<i>D<sub>s min</sub></i>	<i>d<sub>h max</sub></i>	<i>R<sub>max</sub></i>	
10	26	8	0.3	4550	1960	29000	34000	<b>6000</b>	12.5	23.5	0.3	0.019
12	28	8	0.3	5100	2390	26000	30000	<b>6001</b>	14.5	25.5	0.3	0.021
15	32	9	0.3	5600	2840	22000	26000	<b>6002</b>	17.5	29.5	0.3	0.030
17	35	10	0.3	6800	3350	20000	24000	<b>6003</b>	19.5	32.5	0.3	0.039
20	42	12	0.6	9400	5050	18000	21000	<b>6004</b>	25.0	37.0	0.6	0.069
25	47	12	0.6	10100	5850	15000	18000	<b>6005</b>	30.0	42.0	0.6	0.080
30	55	13	1.0	13200	8300	13000	15000	<b>6006</b>	36.0	49.0	1.0	0.116
35	62	14	1.0	16000	10300	12000	14000	<b>6007</b>	41.0	56.0	1.0	0.155
40	68	15	1.0	16800	11500	10000	12000	<b>6008</b>	46.0	62.0	1.0	0.190
45	75	16	1.0	21000	15100	9200	11000	<b>6009</b>	51.0	69.0	1.0	0.237
50	80	16	1.0	21800	16600	8400	9800	<b>6010</b>	56.0	74.0	1.0	0.261
55	90	18	1.1	28300	21200	7700	9000	<b>6011</b>	62.0	83.0	1.0	0.388
60	95	18	1.1	29500	23200	7000	8300	<b>6012</b>	67.0	88.0	1.0	0.414
65	100	18	1.1	30500	25200	6500	7700	<b>6013</b>	72.0	93.0	1.0	0.421
70	110	20	1.1	38000	31000	6100	7100	<b>6014</b>	77.0	103.0	1.0	0.604
75	115	20	1.1	39500	33500	5700	6700	<b>6015</b>	82.0	108.0	1.0	0.649
80	125	22	1.1	47500	40000	5300	6200	<b>6016</b>	87.0	118.0	1.0	0.854
85	130	22	1.1	49500	43000	5000	5900	<b>6017</b>	92.0	123.0	1.0	0.890
90	140	24	1.5	58000	49500	4700	5600	<b>6018</b>	98.5	131.5	1.5	1.020
95	145	24	1.5	60500	54000	4500	5300	<b>6019</b>	103.5	136.5	1.5	1.080
100	150	24	1.5	60000	54000	4200	5000	<b>6020</b>	108.5	141.5	1.5	1.150

**BALL BEARING**

**SERIES 60..LLB, 60..ZZ**

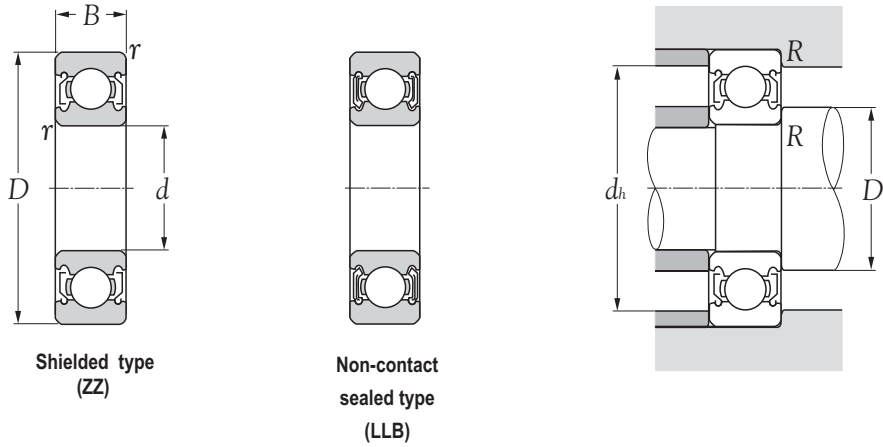

Boundary dimensions mm				Basic load ratings dynamic static N		Limiting speeds rpm		Bearing numbers		Abutment and fillet dimensions mm				Mass kg
<i>d</i>	<i>D</i>	<i>B</i>	<i>r<sub>s min</sub><sup>1)</sup></i>	<i>C<sub>r</sub></i>	<i>C<sub>or</sub></i>	grease	oil			<i>D<sub>s</sub></i> <i>min</i>	<i>D<sub>s</sub></i> <i>max</i>	<i>d<sub>h</sub></i> <i>max</i>	<i>R</i> <i>max</i>	(approx.)
10	26	8	0.3	4550	1960	29000	21000	<b>6000LLB</b>	<b>6000ZZ</b>	12.5	13.5	23.5	0.3	0.019
12	28	8	0.3	5100	2390	26000	18000	<b>6001LLB</b>	<b>6001ZZ</b>	14.5	16.0	25.5	0.3	0.021
15	32	9	0.3	5600	2840	22000	15000	<b>6002LLB</b>	<b>6002ZZ</b>	17.5	19.0	29.5	0.3	0.030
17	35	10	0.3	6800	3350	20000	14000	<b>6003LLB</b>	<b>6003ZZ</b>	19.5	21.0	32.5	0.3	0.039
20	42	12	0.6	9400	5050	18000	11000	<b>6004LLB</b>	<b>6004ZZ</b>	25.0	26.0	37.0	0.6	0.069
25	47	12	0.6	10100	5850	15000	9400	<b>6005LLB</b>	<b>6005ZZ</b>	30.0	30.5	42.0	0.6	0.080
30	55	13	1.0	13200	8300	13000	7700	<b>6006LLB</b>	<b>6006ZZ</b>	36.0	37.0	49.0	1.0	0.116
35	62	14	1.0	16000	10300	12000	6800	<b>6007LLB</b>	<b>6007ZZ</b>	41.0	42.0	56.0	1.0	0.155
40	68	15	1.0	16800	11500	10000	6100	<b>6008LLB</b>	<b>6008ZZ</b>	46.0	47.0	62.0	1.0	0.190
45	75	16	1.0	21000	15100	9200	5400	<b>6009LLB</b>	<b>6009ZZ</b>	51.0	52.5	69.0	1.0	0.237
50	80	16	1.0	21800	16600	8400	5000	<b>6010LLB</b>	<b>6010ZZ</b>	56.0	57.5	74.0	1.0	0.261
55	90	18	1.1	28300	21200	7700	4500	<b>6011LLB</b>	<b>6011ZZ</b>	62.0	64.0	83.0	1.0	0.388
60	95	18	1.1	29500	23200	7000	4100	<b>6012LLB</b>	<b>6012ZZ</b>	67.0	69.0	88.0	1.0	0.414
65	100	18	1.1	30500	25200	6500	3900	<b>6013LLB</b>	<b>6013ZZ</b>	72.0	73.0	93.0	1.0	0.421
70	110	20	1.1	38000	31000	6100	3600	<b>6014LLB</b>	<b>6014ZZ</b>	77.0	80.5	103.0	1.0	0.604
75	115	20	1.1	39500	33500	5700	3300	<b>6015LLB</b>	<b>6015ZZ</b>	82.0	85.5	108.0	1.0	0.649
80	125	22	1.1	47500	40000	5300	3100	<b>6016LLB</b>	<b>6016ZZ</b>	87.0	91.5	118.0	1.0	0.854
85	130	22	1.1	49500	43000	5000	2900	<b>6017LLB</b>	<b>6017ZZ</b>	92.0	97.0	123.0	1.0	0.890
90	140	24	1.5	58000	49500	4700	2800	<b>6018LLB</b>	<b>6018ZZ</b>	98.5	102.0	131.5	1.5	1.020
95	145	24	1.5	60500	54000	4500	2600	<b>6019LLB</b>	<b>6019ZZ</b>	103.5	109.0	136.5	1.5	1.080
100	150	24	1.5	60000	54000	4200	2600	<b>6020LLB</b>	<b>6020ZZ</b>	108.5	110.0	141.5	1.5	1.150



**BALL BEARING**  
**SERIES 62**

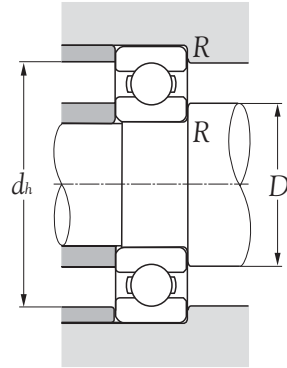
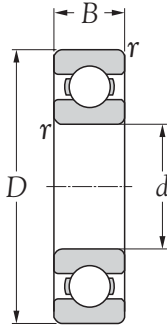

Boundary dimensions mm				Basic load ratings dynamic static N		Limiting speeds rpm		Bearing numbers	Abutment and fillet dimensions mm			Mass kg (approx.)
d	D	B	$r_{s \min}^{1)}$	$C_r$	$C_{or}$	grease	oil		$D_s$ min	$d_h$ max	R max	
10	30	9	0.6	5100	2390	25000	30000	<b>6200</b>	15.0	25.0	0.6	0.032
12	32	10	0.6	6100	2750	22000	26000	<b>6201</b>	17.0	27.0	0.6	0.037
15	35	11	0.6	7750	3600	19000	23000	<b>6202</b>	20.0	30.0	0.6	0.045
17	40	12	0.6	9600	4600	18000	21000	<b>6203</b>	22.0	35.0	0.6	0.066
20	47	14	1.0	12800	6650	16000	18000	<b>6204</b>	26.0	41.0	1.0	0.106
25	52	15	1.0	14000	7850	13000	15000	<b>6205</b>	31.0	46.0	1.0	0.128
30	62	16	1.0	19500	11300	11000	13000	<b>6206</b>	36.0	56.0	1.0	0.199
35	72	17	1.1	25700	15300	9800	11000	<b>6207</b>	42.0	65.0	1.0	0.288
40	80	18	1.1	29100	17800	8700	10000	<b>6208</b>	47.0	73.0	1.0	0.366
45	85	19	1.1	32500	20400	7800	9200	<b>6209</b>	52.0	78.0	1.0	0.398
50	90	20	1.1	35000	23200	7100	8300	<b>6210</b>	57.0	83.0	1.0	0.454
55	100	21	1.5	43500	29200	6400	7600	<b>6211</b>	63.5	91.5	1.5	0.601
60	110	22	1.5	52500	36000	6000	7000	<b>6212</b>	68.5	101.5	1.5	0.783
65	120	23	1.5	57500	40000	5500	6500	<b>6213</b>	73.5	111.5	1.5	0.990
70	125	24	1.5	62000	44000	5100	6000	<b>6214</b>	78.5	116.5	1.5	1.070
75	130	25	1.5	66000	49500	4800	5600	<b>6215</b>	83.5	121.5	1.5	1.180
80	140	26	2.0	72500	53000	4500	5300	<b>6216</b>	90.0	130.0	2.0	1.400
85	150	28	2.0	83500	64000	4200	5000	<b>6217</b>	95.0	140.0	2.0	1.790
90	160	30	2.0	96000	71500	4000	4700	<b>6218</b>	100.0	150.0	2.0	2.150
95	170	32	2.1	109000	82000	3700	4400	<b>6219</b>	107.0	158.0	2.0	2.620
100	180	34	2.1	122000	93000	3500	4200	<b>6220</b>	112.0	168.0	2.0	3.140

**BALL BEARING**

**SERIES 62..LLB, 62..ZZ**

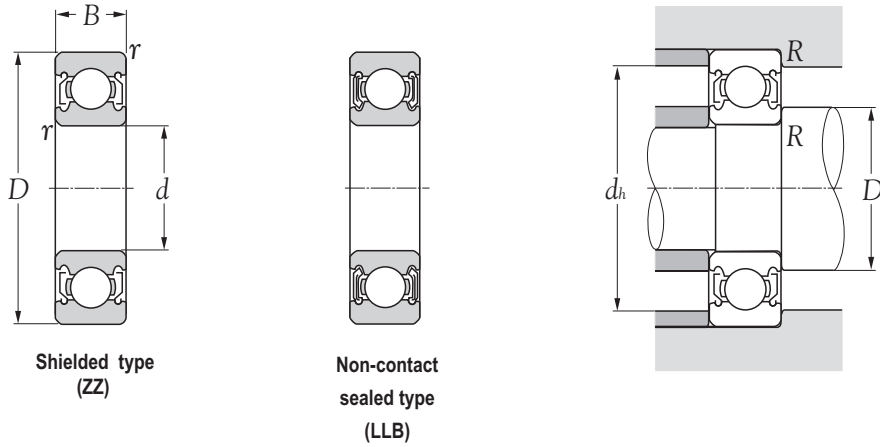

Boundary dimensions				Basic load ratings		Limiting speeds		Bearing numbers		Abutment and fillet dimensions				Mass
mm				dynamic	static	rpm				mm				kg
<i>d</i>	<i>D</i>	<i>B</i>	<i>r<sub>s min</sub><sup>1)</sup></i>	<i>C<sub>r</sub></i>	<i>C<sub>or</sub></i>	grease	oil			<i>D<sub>s</sub></i>	<i>d<sub>h</sub></i>	<i>R</i>	<i>R</i>	(approx.)
					<i>N</i>					<i>min</i>	<i>max</i>	<i>max</i>	<i>max</i>	
10	30	9	0.6	5100	2390	25000	18000	<b>6200LLB</b>	<b>6200ZZ</b>	15.0	16.0	25.0	0.6	0.032
12	32	10	0.6	6100	2750	22000	16000	<b>6201LLB</b>	<b>6201ZZ</b>	17.0	17.5	27.0	0.6	0.037
15	35	11	0.6	7750	3600	19000	15000	<b>6202LLB</b>	<b>6202ZZ</b>	20.0	20.5	30.0	0.6	0.045
17	40	12	0.6	9600	4600	18000	12000	<b>6203LLB</b>	<b>6203ZZ</b>	22.0	23.0	35.0	0.6	0.066
20	47	14	1.0	12800	6650	16000	10000	<b>6204LLB</b>	<b>6204ZZ</b>	26.0	28.0	41.0	1.0	0.106
25	52	15	1.0	14000	7850	13000	8900	<b>6205LLB</b>	<b>6205ZZ</b>	31.0	32.0	46.0	1.0	0.128
30	62	16	1.0	19500	11300	11000	7300	<b>6206LLB</b>	<b>6206ZZ</b>	36.0	39.0	56.0	1.0	0.199
35	72	17	1.1	25700	15300	9800	6300	<b>6207LLB</b>	<b>6207ZZ</b>	42.0	45.0	65.0	1.0	0.288
40	80	18	1.1	29100	17800	8700	5600	<b>6208LLB</b>	<b>6208ZZ</b>	47.0	51.0	73.0	1.0	0.366
45	85	19	1.1	32500	20400	7800	5200	<b>6209LLB</b>	<b>6209ZZ</b>	52.0	55.5	78.0	1.0	0.398
50	90	20	1.1	35000	23200	7100	4700	<b>6210LLB</b>	<b>6210ZZ</b>	57.0	60.0	83.0	1.0	0.454
55	100	21	1.5	43500	29200	6400	4300	<b>6211LLB</b>	<b>6211ZZ</b>	63.5	67.0	91.5	1.5	0.601
60	110	22	1.5	52500	36000	6000	3800	<b>6212LLB</b>	<b>6212ZZ</b>	68.5	75.0	101.5	1.5	0.783
65	120	23	1.5	57500	40000	5500	3600	<b>6213LLB</b>	<b>6213ZZ</b>	73.5	80.5	111.5	1.5	0.990
70	125	24	1.5	62000	44000	5100	3400	<b>6214LLB</b>	<b>6214ZZ</b>	78.5	85.0	116.5	1.5	1.070
75	130	25	1.5	66000	49500	4800	3200	<b>6215LLB</b>	<b>6215ZZ</b>	83.5	90.5	121.5	1.5	1.180
80	140	26	2.0	72500	53000	4500	3000	<b>6216LLB</b>	<b>6216ZZ</b>	90.0	95.5	130.0	2.0	1.400
85	150	28	2.0	83500	64000	4200	2800	<b>6217LLB</b>	<b>6217ZZ</b>	95.0	103.0	140.0	2.0	1.790
90	160	30	2.0	96000	71500	4000	2600	<b>6218LLB</b>	<b>6218ZZ</b>	100.0	109.0	150.0	2.0	2.150
95	170	32	2.1	109000	82000	3700	2500	<b>6219LLB</b>	<b>6219ZZ</b>	107.0	116.0	158.0	2.0	2.620
100	180	34	2.1	122000	93000	3500	2300	<b>6220LLB</b>	<b>6220ZZ</b>	112.0	122.0	168.0	2.0	3.140

**BALL BEARING**  
**SERIES 63**

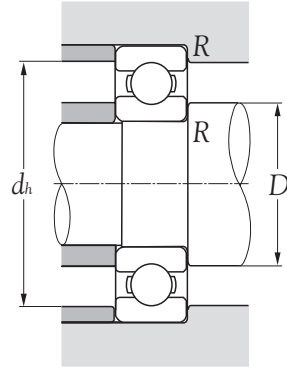
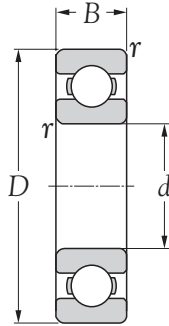

Boundary dimensions mm				Basic load ratings dynamic static N		Limiting speeds rpm		Bearing numbers	Abutment and fillet dimensions mm			Mass kg (approx.)
<i>d</i>	<i>D</i>	<i>B</i>	<i>r<sub>s min</sub><sup>1)</sup></i>	<i>C<sub>r</sub></i>	<i>C<sub>or</sub></i>	grease	oil		<i>D<sub>s min</sub></i>	<i>d<sub>h max</sub></i>	<i>R<sub>max</sub></i>	
10	35	11	0.6	8200	3500	23000	27000	<b>6300</b>	15.0	30.0	0.6	0.053
12	37	12	1.0	9700	4200	20000	24000	<b>6301</b>	18.0	31.0	1.0	0.060
15	42	13	1.0	11400	5450	17000	21000	<b>6302</b>	21.0	36.0	1.0	0.082
17	47	14	1.0	13500	6550	16000	19000	<b>6303</b>	23.0	41.0	1.0	0.115
20	52	15	1.1	15900	7900	14000	17000	<b>6304</b>	27.0	45.0	1.0	0.144
25	62	17	1.1	21200	10900	12000	14000	<b>6305</b>	32.0	55.0	1.0	0.232
30	72	19	1.1	26700	15000	10000	12000	<b>6306</b>	37.0	65.0	1.0	0.360
35	80	21	1.5	33500	19100	8800	10000	<b>6307</b>	43.5	71.5	1.5	0.457
40	90	23	1.5	40500	24000	7800	9200	<b>6308</b>	48.5	81.5	1.5	0.630
45	100	25	1.5	53000	32000	7000	8200	<b>6309</b>	53.5	91.5	1.5	0.814
50	110	27	2.0	62000	38500	6400	7500	<b>6310</b>	60.0	100.0	2.0	1.070
55	120	29	2.0	71500	45000	5800	6800	<b>6311</b>	65.0	110.0	2.0	1.370
60	130	31	2.1	82000	52000	5400	6300	<b>6312</b>	72.0	118.0	2.0	1.730
65	140	33	2.1	92500	60000	4900	5800	<b>6313</b>	77.0	128.0	2.0	2.080
70	150	35	2.1	104000	68000	4600	5400	<b>6314</b>	82.0	138.0	2.0	2.520
75	160	37	2.1	113000	77000	4300	5000	<b>6315</b>	87.0	148.0	2.0	3.020
80	170	39	2.1	123000	86500	4000	4700	<b>6316</b>	92.0	158.0	2.0	3.590
85	180	41	3.0	133000	97000	3800	4500	<b>6317</b>	99.0	166.0	2.5	4.230
90	190	43	3.0	143000	107000	3600	4200	<b>6318</b>	104.0	176.0	2.5	4.910
95	200	45	3.0	153000	119000	3300	3900	<b>6319</b>	109.0	186.0	2.5	5.670
100	215	47	3.0	173000	141000	3200	3700	<b>6320</b>	114.0	201.0	2.5	7.000

**BALL BEARING**

**SERIES 63..LLB, 63..ZZ**

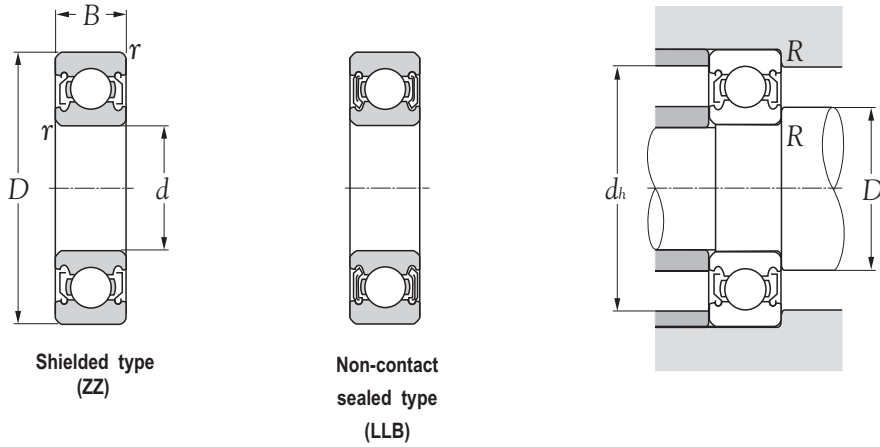

Boundary dimensions mm				Basic load ratings dynamic static N		Limiting speeds rpm		Bearing numbers		Abutment and fillet dimensions mm				Mass kg
<i>d</i>	<i>D</i>	<i>B</i>	<i>r<sub>s min</sub><sup>1)</sup></i>	<i>C<sub>r</sub></i>	<i>C<sub>or</sub></i>	grease	oil			<i>D<sub>s</sub></i> <i>min</i>	<i>D<sub>s</sub></i> <i>max</i>	<i>d<sub>h</sub></i> <i>max</i>	<i>R</i> <i>max</i>	(approx.)
10	35	11	0.6	8200	3500	23000	16000	<b>6300LLB</b>	<b>6300ZZ</b>	15.0	17.0	30.0	0.6	0.053
12	37	12	1.0	9700	4200	20000	15000	<b>6301LLB</b>	<b>6301ZZ</b>	18.0	18.5	31.0	1.0	0.060
15	42	13	1.0	11400	5450	17000	12000	<b>6302LLB</b>	<b>6302ZZ</b>	21.0	23.0	36.0	1.0	0.082
17	47	14	1.0	13500	6550	16000	11000	<b>6303LLB</b>	<b>6303ZZ</b>	23.0	25.0	41.0	1.0	0.115
20	52	15	1.1	15900	7900	14000	10000	<b>6304LLB</b>	<b>6304ZZ</b>	27.0	28.5	45.0	1.0	0.144
25	62	17	1.1	21200	10900	12000	8100	<b>6305LLB</b>	<b>6305ZZ</b>	32.0	35.0	55.0	1.0	0.232
30	72	19	1.1	26700	15000	10000	6600	<b>6306LLB</b>	<b>6306ZZ</b>	37.0	43.0	65.0	1.0	0.360
35	80	21	1.5	33500	19100	8800	6000	<b>6307LLB</b>	<b>6307ZZ</b>	43.5	47.0	71.5	1.5	0.457
40	90	23	1.5	40500	24000	7800	5300	<b>6308LLB</b>	<b>6308ZZ</b>	48.5	54.0	81.5	1.5	0.630
45	100	25	1.5	53000	32000	7000	4700	<b>6309LLB</b>	<b>6309ZZ</b>	53.5	61.5	91.5	1.5	0.814
50	110	27	2.0	62000	38500	6400	4200	<b>6310LLB</b>	<b>6310ZZ</b>	60.0	68.5	100.0	2.0	1.070
55	120	29	2.0	71500	45000	5800	3900	<b>6311LLB</b>	<b>6311ZZ</b>	65.0	74.0	110.0	2.0	1.370
60	130	31	2.1	82000	52000	5400	3600	<b>6312LLB</b>	<b>6312ZZ</b>	72.0	80.5	118.0	2.0	1.730
65	140	33	2.1	92500	60000	4900	3300	<b>6313LLB</b>	<b>6313ZZ</b>	77.0	86.0	128.0	2.0	2.080
70	150	35	2.1	104000	68000	4600	3100	<b>6314LLB</b>	<b>6314ZZ</b>	82.0	92.5	138.0	2.0	2.520
75	160	37	2.1	113000	77000	4300	2900	<b>6315LLB</b>	<b>6315ZZ</b>	87.0	99.0	148.0	2.0	3.020
80	170	39	2.1	123000	86500	4000	2700	<b>6316LLB</b>	<b>6316ZZ</b>	92.0	105.0	158.0	2.0	3.590
85	180	41	3.0	133000	97000	3800	2600	<b>6317LLB</b>	<b>6317ZZ</b>	99.0	112.0	166.0	2.5	4.230
90	190	43	3.0	143000	107000	3600	2400	<b>6318LLB</b>	<b>6318ZZ</b>	104.0	118.0	176.0	2.5	4.910
95	200	45	3.0	153000	119000	3300	2300	-	<b>6319ZZ</b>	109.0	125.0	186.0	2.5	5.670
100	215	47	3.0	173000	141000	3200	2200	-	<b>6320ZZ</b>	114.0	133.0	201.0	2.5	7.000

**BALL BEARING  
SERIES 160**

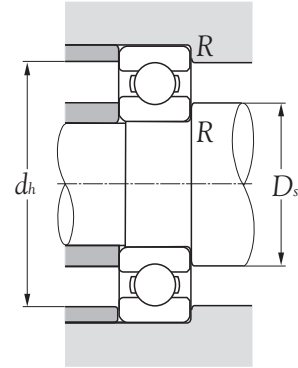
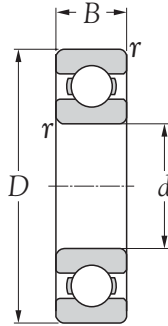

Boundary dimensions mm				Basic load ratings dynamic static N		Limiting speeds rpm		Bearing numbers	Abutment and fillet dimensions mm			Mass kg (approx.)
<i>d</i>	<i>D</i>	<i>B</i>	<i>r<sub>s min</sub><sup>1)</sup></i>	<i>C<sub>r</sub></i>	<i>C<sub>or</sub></i>	grease	oil		<i>D<sub>s min</sub></i>	<i>d<sub>h max</sub></i>	<i>R<sub>max</sub></i>	
12	28	7	0.3	5100	2390	26000	30000	<b>16001</b>	14.5	25.5	0.3	0.019
15	32	8	0.3	5600	2840	22000	26000	<b>16002</b>	17.5	29.5	0.3	0.025
17	35	8	0.3	6800	3350	20000	24000	<b>16003</b>	19.5	32.5	0.3	0.032
20	42	8	0.3	7900	4500	18000	21000	<b>16004</b>	22.5	39.5	0.3	0.051
25	47	8	0.3	8350	5100	15000	18000	<b>16005</b>	27.5	44.5	0.3	0.060
30	55	9	0.3	11200	7350	13000	15000	<b>16006</b>	32.5	52.5	0.3	0.091
35	62	9	0.3	11700	8200	12000	14000	<b>16007</b>	37.5	59.5	0.3	0.110
40	68	9	0.3	12600	9650	10000	12000	<b>16008</b>	42.5	65.5	0.3	0.125
45	75	10	0.6	12900	10500	9200	11000	<b>16009</b>	50.0	70.0	0.6	0.171
50	80	10	0.6	13200	11300	8400	9800	<b>16010</b>	55.0	75.0	0.6	0.180
55	90	11	0.6	18600	15300	7700	9000	<b>16011</b>	60.0	85.0	0.6	0.258
60	95	11	0.6	20000	17500	7000	8300	<b>16012</b>	65.0	90.0	0.6	0.283
65	100	11	0.6	20500	18700	6500	7700	<b>16013</b>	70.0	95.0	0.6	0.307
70	110	13	0.6	24400	22600	6100	7100	<b>16014</b>	75.0	105.0	0.6	0.441
75	115	13	0.6	25000	24000	5700	6700	<b>16015</b>	80.0	110.0	0.6	0.464
80	125	14	0.6	25400	25100	5300	6200	<b>16016</b>	85.0	120.0	0.6	0.597
85	130	14	0.6	25900	26200	5000	5900	<b>16017</b>	90.0	125.0	0.6	0.626
90	140	16	1.0	33500	33500	4700	5600	<b>16018</b>	96.0	134.0	1.0	0.848
95	145	16	1.0	34500	35000	4500	5300	<b>16019</b>	101.0	139.0	1.0	0.885
100	150	16	1.0	35000	36500	4200	5000	<b>16020</b>	106.0	144.0	1.0	0.910
105	160	18	1.0	52000	50500	4000	4700	<b>16021</b>	111.0	154.0	1.0	1.200
110	170	19	1.0	57500	56500	3800	4500	<b>16022</b>	116.0	164.0	1.0	1.460
120	180	19	1.0	63000	63500	3500	4100	<b>16024</b>	126.0	174.0	1.0	1.560

**BALL BEARING**  
**SERIES 68**

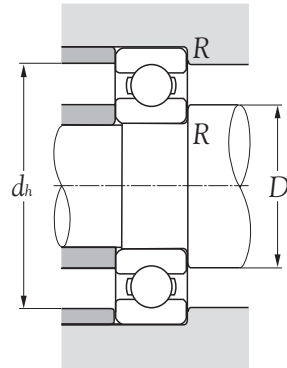
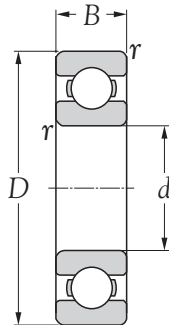

Boundary dimensions mm				Basic load ratings dynamic static N		Limiting speeds rpm		Bearing numbers	Abutment and fillet dimensions mm			Mass kg (approx.)
<i>d</i>	<i>D</i>	<i>B</i>	<i>r<sub>s min</sub><sup>1)</sup></i>	<i>C<sub>r</sub></i>	<i>C<sub>or</sub></i>	grease	oil		<i>D<sub>s min</sub></i>	<i>d<sub>h max</sub></i>	<i>R<sub>max</sub></i>	
10	19	5	0.3	1830	925	32000	38000	<b>6800</b>	12	17	0.3	0.005
12	21	5	0.3	1920	1040	29000	35000	<b>6801</b>	14	19	0.3	0.006
15	24	5	0.3	2080	1260	26000	31000	<b>6802</b>	17	22	0.3	0.007
17	26	5	0.3	2810	1720	24000	28000	<b>6803</b>	19	24	0.3	0.008
20	32	7	0.3	4000	2470	21000	25000	<b>6804</b>	22	30	0.3	0.019
25	37	7	0.3	4300	2950	18000	21000	<b>6805</b>	27	35	0.3	0.022
30	42	7	0.3	4700	3650	15000	18000	<b>6806</b>	32	40	0.3	0.026
35	47	7	0.3	4900	4050	13000	16000	<b>6807</b>	37	45	0.3	0.029
40	52	7	0.3	5100	4400	12000	14000	<b>6808</b>	42	50	0.3	0.033
45	58	7	0.3	6400	5650	11000	12000	<b>6809</b>	47	56	0.3	0.040
50	65	7	0.3	6600	6100	9600	11000	<b>6810</b>	52	63	0.3	0.052
55	72	9	0.3	8800	8100	8700	10000	<b>6811</b>	57	70	0.3	0.083
60	78	10	0.3	11500	10600	8000	9400	<b>6812</b>	62	76	0.3	0.106
65	85	10	0.6	11600	11000	7400	8700	<b>6813</b>	69	81	0.6	0.128
70	90	10	0.6	12100	11900	6900	8100	<b>6814</b>	74	86	0.6	0.137
75	95	10	0.6	12500	12900	6400	7600	<b>6815</b>	79	91	0.6	0.145
80	100	10	0.6	12700	13300	6000	7100	<b>6816</b>	84	96	0.6	0.154

**BALL BEARING**

**SERIES 68..LLB, 68..ZZ**

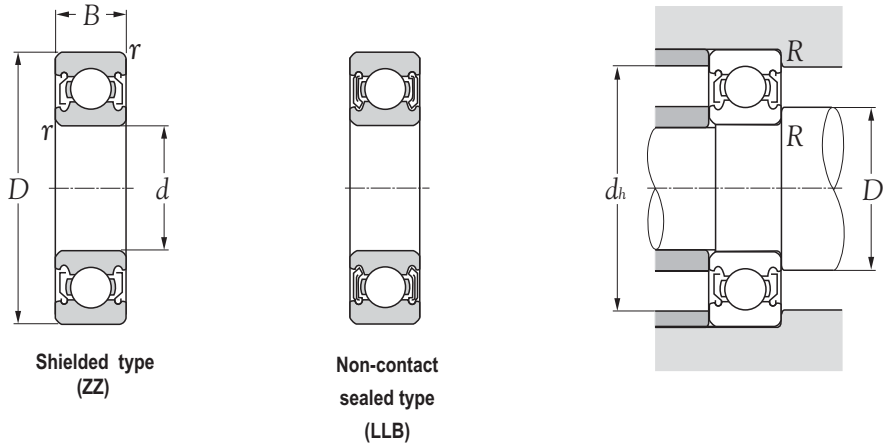

Boundary dimensions mm				Basic load ratings dynamic static N		Limiting speeds rpm		Bearing numbers		Abutment and fillet dimensions mm				Mass kg
<i>d</i>	<i>D</i>	<i>B</i>	<i>r<sub>s min</sub><sup>1)</sup></i>	<i>C<sub>r</sub></i>	<i>C<sub>or</sub></i>	grease	oil			<i>D<sub>s</sub></i> <i>min</i>	<i>D<sub>s</sub></i> <i>max</i>	<i>d<sub>h</sub></i> <i>max</i>	<i>R</i> <i>max</i>	(approx.)
10	19	5	0.3	1830	925	32000	24000	<b>6800LLB</b>	<b>6800ZZ</b>	12	12.5	17	0.3	0.005
12	21	5	0.3	1920	1040	29000	20000	<b>6801LLB</b>	<b>6801ZZ</b>	14	14.5	19	0.3	0.006
15	24	5	0.3	2080	1260	26000	17000	<b>6802LLB</b>	<b>6802ZZ</b>	17	17.5	22	0.3	0.007
17	26	5	0.3	2810	1720	24000	15000	<b>6803LLB</b>	<b>6803ZZ</b>	19	19.5	24	0.3	0.008
20	32	7	0.3	4000	2470	21000	13000	<b>6804LLB</b>	<b>6804ZZ</b>	22	23.0	30	0.3	0.019
25	37	7	0.3	4300	2950	18000	10000	<b>6805LLB</b>	<b>6805ZZ</b>	27	28.0	35	0.3	0.022
30	42	7	0.3	4700	3650	15000	8800	<b>6806LLB</b>	<b>6806ZZ</b>	32	33.0	40	0.3	0.026
35	47	7	0.3	4900	4050	13000	7600	<b>6807LLB</b>	<b>6807ZZ</b>	37	38.0	45	0.3	0.029
40	52	7	0.3	5100	4400	12000	6700	<b>6808LLB</b>	<b>6808ZZ</b>	42	43.0	50	0.3	0.033
45	58	7	0.3	6400	5650	11000	5900	<b>6809LLB</b>	<b>6809ZZ</b>	47	48.0	56	0.3	0.040
50	65	7	0.3	6600	6100	9600	5300	<b>6810LLB</b>	<b>6810ZZ</b>	52	54.0	63	0.3	0.052
55	72	9	0.3	8800	8100	8700	4800	<b>6811LLB</b>	<b>6811ZZ</b>	57	59.0	70	0.3	0.083
60	78	10	0.3	11500	10600	8000	4400	<b>6812LLB</b>	<b>6812ZZ</b>	62	64.5	76	0.3	0.106
65	85	10	0.6	11600	11000	7400	4100	<b>6813LLB</b>	<b>6813ZZ</b>	69	70.0	81	0.6	0.128
70	90	10	0.6	12100	11900	6900	3800	<b>6814LLB</b>	<b>6814ZZ</b>	74	75.5	86	0.6	0.137
75	95	10	0.6	12500	12900	6400	3600	<b>6815LLB</b>	<b>6815ZZ</b>	79	80.0	91	0.6	0.145
80	100	10	0.6	12700	13300	6000	3400	<b>6816LLB</b>	<b>6816ZZ</b>	84	85.0	96	0.6	0.154

**BALL BEARING**  
**SERIES 69**

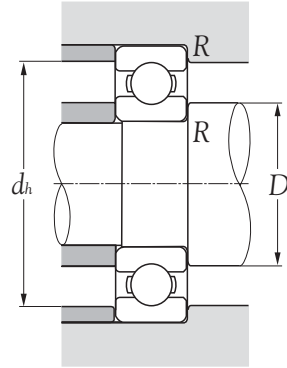
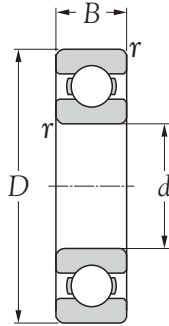

Boundary dimensions mm				Basic load ratings dynamic static N		Limiting speeds rpm		Bearing numbers	Abutment and fillet dimensions mm			Mass kg (approx.)
<i>d</i>	<i>D</i>	<i>B</i>	<i>r<sub>s min</sub><sup>1)</sup></i>	<i>C<sub>r</sub></i>	<i>C<sub>or</sub></i>	grease	oil		<i>D<sub>s min</sub></i>	<i>d<sub>h max</sub></i>	<i>R<sub>max</sub></i>	
10	22	6	0.3	2700	1270	30000	36000	<b>6900</b>	12	20	0.3	0.009
12	24	6	0.3	2890	1460	27000	32000	<b>6901</b>	14	22	0.3	0.011
15	28	7	0.3	4100	2060	24000	28000	<b>6902</b>	17	26	0.3	0.016
17	30	7	0.3	4650	2580	22000	26000	<b>6903</b>	19	28	0.3	0.018
20	37	9	0.3	6400	3700	19000	23000	<b>6904</b>	22	35	0.3	0.036
25	42	9	0.3	7050	4550	16000	19000	<b>6905</b>	27	40	0.3	0.042
30	47	9	0.3	7250	5000	14000	17000	<b>6906</b>	32	45	0.3	0.048
35	55	10	0.6	11200	7450	12000	15000	<b>6907</b>	39	51	0.6	0.074
40	62	12	0.6	14600	10200	11000	13000	<b>6908</b>	44	58	0.6	0.110
45	68	12	0.6	15100	11200	9800	12000	<b>6909</b>	49	64	0.6	0.128
50	72	12	0.6	15600	12200	8900	11000	<b>6910</b>	54	68	0.6	0.132
55	80	13	1.0	16000	13300	8200	9600	<b>6911</b>	60	75	1.0	0.180
60	85	13	1.0	16400	14300	7600	8900	<b>6912</b>	65	80	1.0	0.193
65	90	13	1.0	17400	16100	7000	8200	<b>6913</b>	70	85	1.0	0.206
70	100	16	1.0	23700	21200	6500	7700	<b>6914</b>	75	95	1.0	0.334
75	105	16	1.0	24400	22600	6100	7200	<b>6915</b>	80	100	1.0	0.353
80	110	16	1.0	24900	24000	5700	6700	<b>6916</b>	85	105	1.0	0.373



**BALL BEARING**

**SERIES 69..LLB, 69..ZZ**

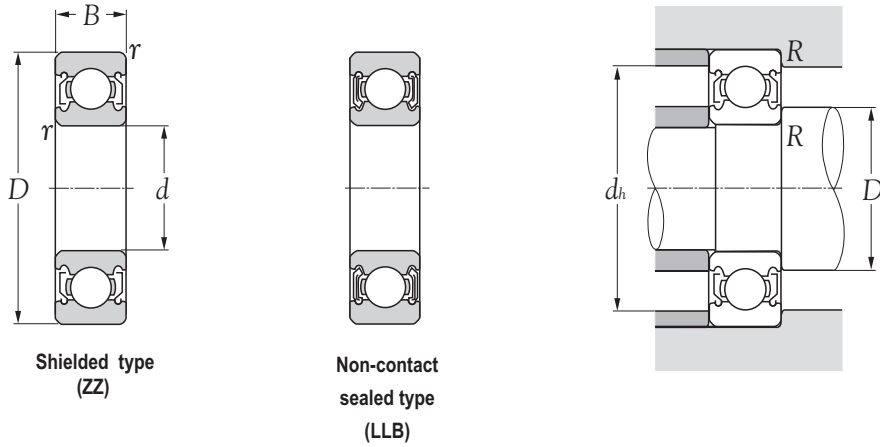

Boundary dimensions mm				Basic load ratings dynamic static N		Limiting speeds rpm		Bearing numbers		Abutment and fillet dimensions mm				Mass kg
<i>d</i>	<i>D</i>	<i>B</i>	<i>r<sub>s min</sub><sup>1)</sup></i>	<i>C<sub>r</sub></i>	<i>C<sub>or</sub></i>	grease	oil			<i>D<sub>s</sub></i> <i>min</i>	<i>D<sub>s</sub></i> <i>max</i>	<i>d<sub>h</sub></i> <i>max</i>	<i>R</i> <i>max</i>	(approx.)
10	22	6	0.3	2700	1270	30000	21000	<b>6900LLB</b>	<b>6900ZZ</b>	12	13.0	20	0.3	0.009
12	24	6	0.3	2890	1460	27000	19000	<b>6901LLB</b>	<b>6901ZZ</b>	14	15.0	22	0.3	0.011
15	28	7	0.3	4100	2060	24000	16000	<b>6902LLB</b>	<b>6902ZZ</b>	17	18.0	26	0.3	0.016
17	30	7	0.3	4650	2580	22000	14000	<b>6903LLB</b>	<b>6903ZZ</b>	19	20.0	28	0.3	0.018
20	37	9	0.3	6400	3700	19000	12000	<b>6904LLB</b>	<b>6904ZZ</b>	22	24.0	35	0.3	0.036
25	42	9	0.3	7050	4550	16000	9800	<b>6905LLB</b>	<b>6905ZZ</b>	27	29.0	40	0.3	0.042
30	47	9	0.3	7250	5000	14000	8400	<b>6906LLB</b>	<b>6906ZZ</b>	32	34.0	45	0.3	0.048
35	55	10	0.6	11200	7450	12000	7100	<b>6907LLB</b>	<b>6907ZZ</b>	39	40.0	51	0.6	0.074
40	62	12	0.6	14600	10200	11000	6300	<b>6908LLB</b>	<b>6908ZZ</b>	44	45.0	58	0.6	0.110
45	68	12	0.6	15100	11200	9800	5600	<b>6909LLB</b>	<b>6909ZZ</b>	49	51.0	64	0.6	0.128
50	72	12	0.6	15600	12200	8900	5100	<b>6910LLB</b>	<b>6910ZZ</b>	54	55.5	68	0.6	0.132
55	80	13	1.0	16000	13300	8200	4600	<b>6911LLB</b>	<b>6911ZZ</b>	60	61.5	75	1.0	0.180
60	85	13	1.0	16400	14300	7600	4300	<b>6912LLB</b>	<b>6912ZZ</b>	65	66.5	80	1.0	0.193
65	90	13	1.0	17400	16100	7000	4000	<b>6913LLB</b>	<b>6913ZZ</b>	70	71.5	85	1.0	0.206
70	100	16	1.0	23700	21200	6500	3700	<b>6914LLB</b>	<b>6914ZZ</b>	75	77.5	95	1.0	0.334
75	105	16	1.0	24400	22600	6100	3500	<b>6915LLB</b>	<b>6915ZZ</b>	80	82.5	100	1.0	0.353
80	110	16	1.0	24900	24000	5700	3200	<b>6916LLB</b>	<b>6916ZZ</b>	85	88.0	105	1.0	0.373

**BALL BEARING**  
**SERIES 622..2RS**

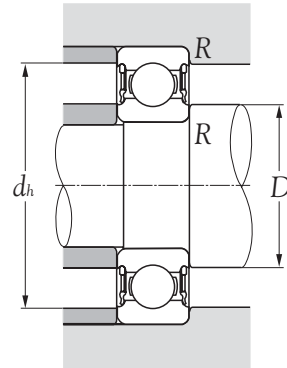
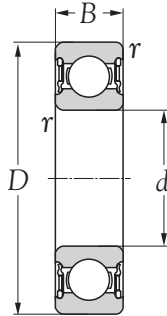

Boundary dimensions mm				Basic load ratings dynamic static N		Speed rating rpm	Bearing numbers	Abutment and fillet dimensions mm				Mass kg (approx.)
<i>d</i>	<i>D</i>	<i>B</i>	<i>r<sub>s min</sub><sup>1)</sup></i>	<i>C<sub>o</sub></i>	<i>C<sub>or</sub></i>			<i>D<sub>s min</sub></i>	<i>D<sub>s max</sub></i>	<i>d<sub>h max</sub></i>	<i>R<sub>max</sub></i>	
10	30	14	0.6	5070	2360	17000	<b>62200 2RS</b>	14.0	14.5	26.0	0.6	0.040
12	32	14	0.6	6890	3100	15000	<b>62201 2RS</b>	16.0	16.0	28.0	0.6	0.045
15	35	14	0.6	7800	3750	13000	<b>62202 2RS</b>	19.0	19.0	31.0	0.6	0.054
17	40	16	0.6	9560	4750	12000	<b>62203 2RS</b>	21.0	21.0	36.0	0.6	0.083
20	47	18	1.0	12700	6550	10000	<b>62204 2RS</b>	25.0	25.5	42.0	1.0	0.130
25	52	18	1.0	14000	7800	8500	<b>62205 2RS</b>	30.0	31.0	47.0	1.0	0.150
30	62	20	1.0	19500	11200	7500	<b>62206 2RS</b>	35.0	37.0	57.0	1.0	0.240
35	72	23	1.1	25500	15300	6300	<b>62207 2RS</b>	41.5	43.5	65.5	1.0	0.370
40	80	23	1.1	30700	19000	5600	<b>62208 2RS</b>	46.5	49.5	73.5	1.0	0.440
45	85	23	1.1	33200	21600	5000	<b>62209 2RS</b>	51.5	54.0	78.5	1.0	0.480
50	90	23	1.1	35100	23200	4800	<b>62210 2RS</b>	56.5	58.0	83.5	1.0	0.520

**BALL BEARING**  
**SERIES 623..2RS**

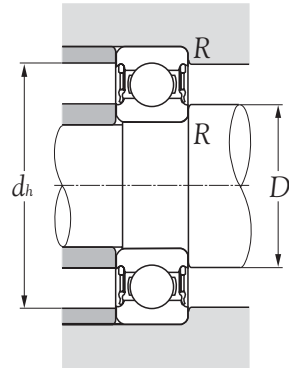
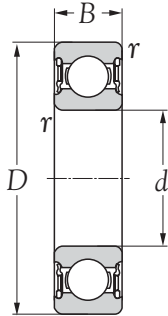

Boundary dimensions mm				Basic load ratings dynamic static N		Speed rating rpm	Bearing numbers	Abutment and fillet dimensions mm				Mass kg (approx.)
<i>d</i>	<i>D</i>	<i>B</i>	<i>r</i> <sub>s min</sub> <sup>1)</sup>	<i>C</i> <sub>o</sub>	<i>C</i> <sub>or</sub>			<i>D</i> <sub>s</sub> <i>min</i>	<i>D</i> <sub>s</sub> <i>max</i>	<i>d</i> <sub>h</sub> <i>max</i>	<i>R</i> <i>max</i>	
10	35	17	0.6	8060	3400	15000	<b>62300 2RS</b>	14.0	15.0	31.0	0.6	0.06
12	37	17	1.0	9750	4150	14000	<b>62301 2RS</b>	17.0	17.0	32.0	1.0	0.07
15	42	17	1.0	11400	5400	12000	<b>62302 2RS</b>	20.0	20.5	37.0	1.0	0.11
17	47	19	1.0	13500	6550	11000	<b>62303 2RS</b>	22.0	23.5	42.0	1.0	0.15
20	52	21	1.1	15900	7800	9500	<b>62304 2RS</b>	26.5	27.0	45.5	1.0	0.20
25	62	24	1.1	22500	11600	7500	<b>62305 2RS</b>	31.5	33.5	55.5	1.0	0.32
30	72	27	1.1	28100	16000	6300	<b>62306 2RS</b>	36.5	41.5	65.5	1.0	0.48
35	80	31	1.5	33200	19000	6000	<b>62307 2RS</b>	43.0	44.0	72.0	1.5	0.66
40	90	33	1.5	41000	24000	5000	<b>62308 2RS</b>	48.0	50.5	82.0	1.5	0.89
45	100	36	1.5	52700	31500	4500	<b>62309 2RS</b>	53.0	56.5	92.0	1.5	1.15
50	110	40	2.0	61800	38000	4300	<b>62310 2RS</b>	59.0	63.0	101.0	2.0	1.55

**BALL BEARING**  
**SERIES 630..2RS**

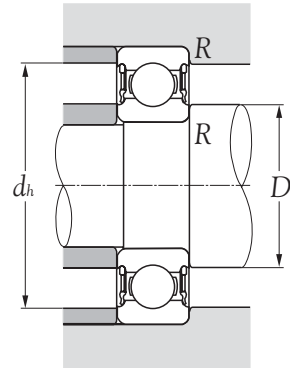
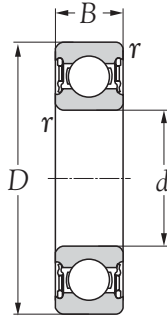

Boundary dimensions mm				Basic load ratings dynamic static N		Speed rating rpm	Bearing numbers	Abutment and fillet dimensions mm				Mass kg (approx.)
<i>d</i>	<i>D</i>	<i>B</i>	<i>r</i> <sub>s min</sub> <sup>1)</sup>	<i>C</i> <sub>o</sub>	<i>C</i> <sub>or</sub>			<i>D</i> <sub>s min</sub>	<i>D</i> <sub>s max</sub>	<i>d</i> <sub>h max</sub>	<i>R</i> <sub>max</sub>	
10	26	12	0.3	4620	1960	19000	<b>63000 2RS</b>	12	12.5	24	0.3	0.025
12	28	12	0.3	5070	2360	17000	<b>63001 2RS</b>	14	14.5	26	0.3	0.029
15	32	13	0.3	5590	2850	14000	<b>63002 2RS</b>	17	18.0	30	0.3	0.039
17	35	14	0.3	6050	3250	13000	<b>63003 2RS</b>	19	20.0	33	0.3	0.052
20	42	16	0.6	9360	5000	11000	<b>63004 2RS</b>	24	24.5	38	0.6	0.086
25	47	16	0.6	11200	6550	9500	<b>63005 2RS</b>	29	29.0	43	0.6	0.100
30	55	19	1.0	13300	8300	8000	<b>63006 2RS</b>	35	35.5	50	1.0	0.160
35	62	20	1.0	15900	10200	7000	<b>63007 2RS</b>	40	40.5	57	1.0	0.210
40	68	21	1.0	16800	11600	6300	<b>63008 2RS</b>	45	46.0	63	1.0	0.260
45	75	23	1.0	20800	14600	5600	<b>63009 2RS</b>	50	51.0	70	1.0	0.340
50	80	23	1.0	21600	16000	5000	<b>63010 2RS</b>	55	56.0	75	1.0	0.370

**BALL BEARING**  
**SERIES 64**

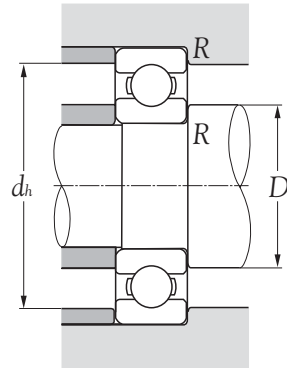
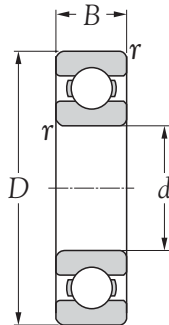

Boundary dimensions mm				Basic load ratings dynamic static N		Limiting speeds rpm		Bearing numbers	Abutment and fillet dimensions mm			Mass kg (approx.)
<i>d</i>	<i>D</i>	<i>B</i>	<i>r<sub>s min</sub><sup>1)</sup></i>	<i>C<sub>r</sub></i>	<i>C<sub>or</sub></i>	grease	oil		<i>D<sub>s min</sub></i>	<i>d<sub>h max</sub></i>	<i>R<sub>max</sub></i>	
17	62	17	1.1	22700	10800	14000	16000	<b>6403</b>	24.0	55.0	1.0	0.270
20	72	19	1.1	28500	13900	12000	14000	<b>6404</b>	27.0	65.0	1.0	0.400
25	80	21	1.5	34500	17500	10000	12000	<b>6405</b>	33.5	71.5	1.5	0.530
30	90	23	1.5	43500	23900	8800	10000	<b>6406</b>	38.5	81.5	1.5	0.735
35	100	25	1.5	55000	31000	7800	9100	<b>6407</b>	43.5	91.5	1.5	0.952
40	110	27	2.0	63500	36500	7000	8200	<b>6408</b>	50.0	100.0	2.0	1.230
45	120	29	2.0	77000	45000	6300	7400	<b>6409</b>	55.0	110.0	2.0	1.530
50	130	31	2.1	83000	49500	5700	6700	<b>6410</b>	62.0	118.0	2.0	1.880
55	140	33	2.1	89000	54000	5200	6100	<b>6411</b>	67.0	128.0	2.0	2.290
60	150	35	2.1	102000	64500	4800	5700	<b>6412</b>	72.0	138.0	2.0	2.770

**BALL BEARING**  
**SERIES 52**

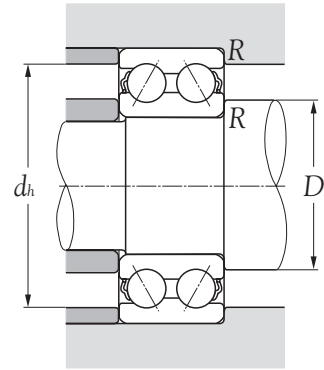
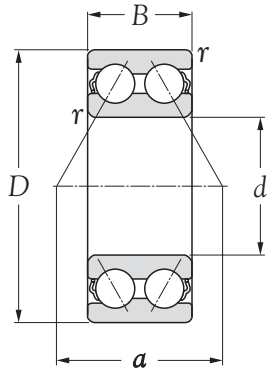

Boundary dimensions mm				Basic load ratings dynamic static N		Limiting speeds rpm		Bearing numbers	Abutment and fillet dimensions mm				Mass kg (approx.)
<i>d</i>	<i>D</i>	<i>B</i>	<i>r</i> <sub>s min</sub> <sup>1)</sup>	<i>C<sub>r</sub></i>	<i>C<sub>or</sub></i>	grease	oil		<i>D<sub>s</sub></i> <i>min</i>	<i>d<sub>h</sub></i> <i>max</i>	<i>R</i> <i>max</i>	<i>a</i>	
10	30	14.3	0.6	6950	3800	14000	19000	<b>5200</b>	15	25	0.6	17.5	0.049
12	32	15.9	0.6	9150	5050	13000	17000	<b>5201</b>	17	27	0.6	19.0	0.057
15	35	15.9	0.6	10000	6050	11000	15000	<b>5202</b>	20	30	0.6	21.0	0.064
17	40	17.5	0.6	12800	7900	9900	13000	<b>5203</b>	22	35	0.6	24.0	0.096
20	47	20.6	1.0	19000	12100	8800	12000	<b>5204</b>	26	41	1.0	28.0	0.153
25	52	20.6	1.0	20600	14300	7300	9800	<b>5205</b>	31	46	1.0	31.5	0.175
30	62	23.8	1.0	28600	20400	6300	8400	<b>5206</b>	36	56	1.0	36.5	0.286
35	72	27.0	1.1	38000	27800	5500	7400	<b>5207</b>	42	65	1.0	42.5	0.436
40	80	30.2	1.1	42500	32500	4900	6600	<b>5208</b>	47	73	1.0	47.5	0.590
45	85	30.2	1.1	48000	37000	4400	5900	<b>5209</b>	52	78	1.0	50.5	0.640
50	90	30.2	1.1	51000	42000	4000	5300	<b>5210</b>	57	83	1.0	54.0	0.689

**BALL BEARING**  
**SERIES 52..2RS**

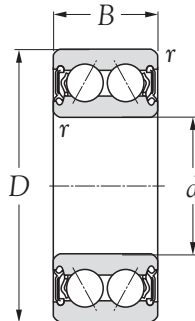

Boundary dimensions				Basic load ratings		Limiting speeds		Bearing numbers	Mass kg (approx.)
mm				dynamic	static	rpm			
<i>d</i>	<i>D</i>	<i>B</i>	<i>r</i> s min <sup>-1</sup> )	<i>C<sub>r</sub></i>	<i>C<sub>0r</sub></i>	grease	oil		
10	30	14.3	0.6	7150	3900	16000	22000	<b>5200 2RS</b>	0.045
12	32	15.9	0.6	10600	5850	15000	20000	<b>5201 2RS</b>	0.050
15	35	15.9	0.6	11700	6950	12000	17000	<b>5202 2RS</b>	0.068
17	40	17.5	0.6	14800	9000	10000	15000	<b>5203 2RS</b>	0.090
20	47	20.6	1.0	19500	12200	9000	13000	<b>5204 2RS</b>	0.140
25	52	20.6	1.0	21200	14600	8000	11000	<b>5205 2RS</b>	0.160
30	62	23.8	1.0	29600	21200	7000	9500	<b>5206 2RS</b>	0.260
35	72	27.0	1.1	37700	27500	6000	8000	<b>5207 2RS</b>	0.400
40	80	30.2	1.1	44900	34000	5600	7500	<b>5208 2RS</b>	0.530
45	85	30.2	1.1	48800	39000	5000	6700	<b>5209 2RS</b>	0.570

**BALL BEARING**  
**SERIES 53**

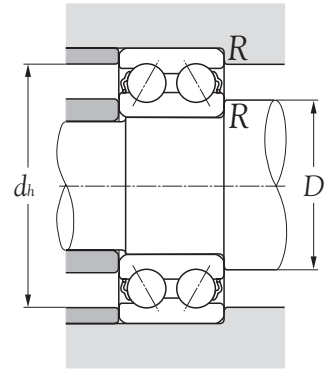
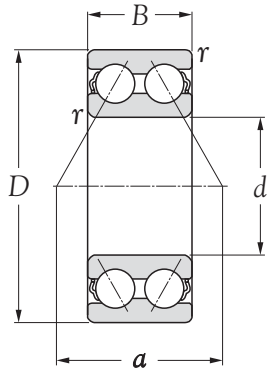

Boundary dimensions mm				Basic load ratings dynamic static N		Limiting speeds rpm		Bearing numbers	Abutment and fillet dimensions mm				Mass kg (approx.)
$d$	$D$	$B$	$r_{s \min}^{1)}$	$C_r$	$C_{or}$	grease	oil		$D_{s \min}$	$d_{h \max}$	$R_{\max}$	$a$	
15	42	19.0	1.0	17200	10100	9900	13000	<b>5302</b>	21.0	36.0	1.0	26.0	0.132
17	47	22.2	1.0	20400	12100	9000	12000	<b>5303</b>	23.0	41.0	1.0	28.5	0.181
20	52	22.2	1.1	20600	12700	8000	11000	<b>5304</b>	27.0	45.0	1.0	30.5	0.217
25	62	25.4	1.1	30500	20500	6700	8900	<b>5305</b>	32.0	55.0	1.0	36.5	0.362
30	72	30.2	1.1	39500	27500	5700	7600	<b>5306</b>	37.0	65.0	1.0	43.0	0.553
35	80	34.9	1.5	49500	35000	5000	6600	<b>5307</b>	43.5	71.5	1.5	48.5	0.766
40	90	36.5	1.5	60500	44000	4400	5900	<b>5308</b>	48.5	81.5	1.5	53.5	1.010
45	100	39.7	1.5	72500	54000	4000	5300	<b>5309</b>	53.5	91.5	1.5	60.0	1.340
50	110	44.4	2.0	85500	64500	3600	4800	<b>5310</b>	60.0	100.0	2.0	65.5	1.810



**BALL BEARING**  
**SERIES 53..2RS**

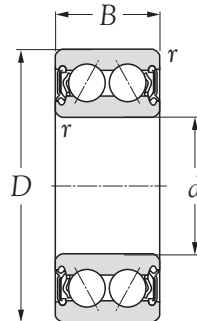

Boundary dimensions				Basic load ratings		Limiting speeds		Bearing numbers	Mass kg (approx.)
mm				dynamic	static	rpm			
<i>d</i>	<i>D</i>	<i>B</i>	<i>r</i> <small>min<sup>1)</sup></small>	<i>C<sub>r</sub></i>	<i>C<sub>0r</sub></i>	grease	oil		
15	42	19.0	1.0	17200	10100	9900	13000	<b>5302 2RS</b>	0.132
17	47	22.2	1.0	20400	12100	9000	12000	<b>5303 2RS</b>	0.181
20	52	22.2	1.1	22500	14600	8500	12000	<b>5304 2RS</b>	0.200
25	62	25.4	1.1	30700	20400	7500	10000	<b>5305 2RS</b>	0.320
30	72	30.2	1.1	41600	29000	6300	8500	<b>5306 2RS</b>	0.480
45	100	39.7	1.5	72800	53000	4500	6000	<b>5309 2RS</b>	1.150

**BALL BEARING**  
**SERIES 12, 12..K**

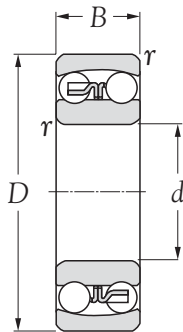

Cylindrical bore

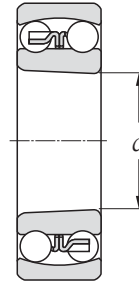

Tapered bore  
taper 1:12

Boundary dimensions mm				Basic load ratings dynamic static N		Limiting speeds rpm		Bearing numbers		Mass kg	
<i>d</i>	<i>D</i>	<i>B</i>	<i>r<sub>s min</sub><sup>b)</sup></i>	<i>C<sub>r</sub></i>	<i>C<sub>or</sub></i>	grease	oil			cylindrical bore	tapered bore
											(approx.)
10	30	9	0.6	5500	1190	21000	24000	<b>1200</b>	-	0.033	-
12	32	10	0.6	5600	1270	18000	22000	<b>1201</b>	-	0.040	-
15	35	11	0.6	7450	1750	16000	19000	<b>1202</b>	-	0.049	-
17	40	12	0.6	7900	2010	14000	17000	<b>1203</b>	-	0.072	-
20	47	14	1.0	9900	2610	13000	15000	<b>1204</b>	<b>1204K</b>	0.116	0.114
25	52	15	1.0	12100	3300	11000	13000	<b>1205</b>	<b>1205K</b>	0.138	0.135
30	62	16	1.0	15600	4650	9200	11000	<b>1206</b>	<b>1206K</b>	0.217	0.213
35	72	17	1.1	15800	5100	8000	9400	<b>1207</b>	<b>1207K</b>	0.317	0.312
40	80	18	1.1	19300	6550	7100	8400	<b>1208</b>	<b>1208K</b>	0.414	0.407
45	85	19	1.1	21900	7350	6400	7500	<b>1209</b>	<b>1209K</b>	0.457	0.448
50	90	20	1.1	22700	8100	5800	6800	<b>1210</b>	<b>1210K</b>	0.515	0.504
55	100	21	1.5	26800	10000	5300	6200	<b>1211</b>	<b>1211K</b>	0.692	0.679
60	110	22	1.5	30000	11500	4900	5800	<b>1212</b>	<b>1212K</b>	0.879	0.864
65	120	23	1.5	31000	12500	4500	5300	<b>1213</b>	<b>1213K</b>	1.130	1.110
70	125	24	1.5	34500	13800	4200	4900	<b>1214</b>	-	1.240	-
75	130	25	1.5	39000	15700	3900	4600	<b>1215</b>	<b>1215K</b>	1.330	1.310
80	140	26	2.0	40000	17000	3700	4300	<b>1216</b>	<b>1216K</b>	1.650	1.620

**BALL BEARING**  
**SERIES 13, 13..K**

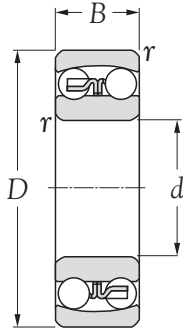

Cylindrical bore

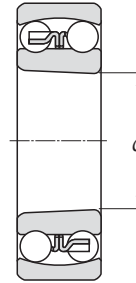

Tapered bore  
taper 1:12

Boundary dimensions mm				Basic load ratings dynamic static N		Limiting speeds rpm		Bearing numbers		Mass kg cylindrical tapered bore bore (approx.)	
<i>d</i>	<i>D</i>	<i>B</i>	<i>r<sub>s min</sub></i> <sup>1)</sup>	<i>C<sub>r</sub></i>	<i>C<sub>or</sub></i>	grease	oil				
10	35	11	0.6	7250	1620	18000	21000	<b>1300</b>	-	0.058	-
12	37	12	1.0	9450	2160	16000	18000	<b>1301</b>	-	0.066	-
15	42	13	1.0	9550	2300	13000	16000	<b>1302</b>	-	0.092	-
17	47	14	1.0	12500	3200	12000	14000	<b>1303</b>	-	0.128	-
20	52	15	1.1	12400	3350	11000	13000	<b>1304</b>	<b>1304K</b>	0.160	0.158
25	62	17	1.1	18000	5000	9100	11000	<b>1305</b>	<b>1305K</b>	0.255	0.251
30	72	19	1.1	21300	6300	7700	9100	<b>1306</b>	<b>1306K</b>	0.383	0.377
35	80	21	1.5	25100	7850	6800	8000	<b>1307</b>	<b>1307K</b>	0.500	0.492
40	90	23	1.5	29600	9700	6000	7000	<b>1308</b>	<b>1308K</b>	0.709	0.698
45	100	25	1.5	38000	12700	5400	6300	<b>1309</b>	<b>1309K</b>	0.953	0.938
50	110	27	2.0	43500	14100	4900	5800	<b>1310</b>	<b>1310K</b>	1.200	1.180
55	120	29	2.0	51500	17900	4500	5200	<b>1311</b>	<b>1311K</b>	1.580	1.560
60	130	31	2.1	57000	20800	4100	4800	<b>1312</b>	<b>1312K</b>	1.960	1.930

**BALL BEARING**  
**SERIES 22, 22..K**

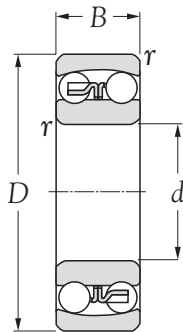

Cylindrical bore

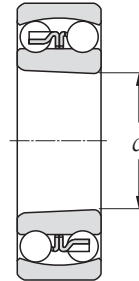

Tapered bore  
taper 1:12

Boundary dimensions				Basic load ratings		Limiting speeds		Bearing numbers		Mass	
mm				dynamic	static	rpm				cylindrical bore	tapered bore
<i>d</i>	<i>D</i>	<i>B</i>	<i>r</i> <i>s min</i> <sup>1)</sup>	<i>C<sub>r</sub></i>	<i>C<sub>or</sub></i>	grease	oil			(approx.)	
10	30	14	0.6	7300	1590	19000	23000	<b>2200</b>	-	0.047	-
12	32	14	0.6	7600	1730	17000	20000	<b>2201</b>	-	0.051	-
15	35	14	0.6	7700	1850	15000	18000	<b>2202</b>	-	0.060	-
17	40	16	0.6	9800	2410	13000	16000	<b>2203</b>	-	0.088	-
20	47	18	1.0	12600	3300	12000	14000	<b>2204</b>	<b>2204K</b>	0.140	0.137
25	52	18	1.0	12300	3450	10000	12000	<b>2205</b>	<b>2205K</b>	0.157	0.153
30	62	20	1.0	15200	4500	8600	10000	<b>2206</b>	<b>2206K</b>	0.256	0.250
35	72	23	1.1	21500	6600	7500	8800	<b>2207</b>	<b>2207K</b>	0.392	0.382
40	80	23	1.1	22300	7350	6700	7900	<b>2208</b>	<b>2208K</b>	0.493	0.482
45	85	23	1.1	23200	8150	6000	7100	<b>2209</b>	<b>2209K</b>	0.540	0.528
50	90	23	1.1	23200	8450	5500	6400	<b>2210</b>	<b>2210K</b>	0.583	0.569
55	100	25	1.5	26500	9900	5000	5800	<b>2211</b>	<b>2211K</b>	0.787	0.769
60	110	28	1.5	34000	12600	4600	5400	<b>2212</b>	<b>2212K</b>	1.080	1.060

**BALL BEARING**  
**SERIES 22..2RS**

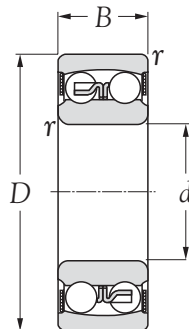

Boundary dimensions				Basic load ratings		Speed rating	Bearing numbers	Mass
mm				dynamic	static	rpm		
<i>d</i>	<i>D</i>	<i>B</i>	<i>r</i> <i>min</i> <sup>b)</sup>	<i>C<sub>r</sub></i>	<i>C<sub>0r</sub></i>	grease		(approx.)
10	30	14	0.6	5530	1180	17000	<b>2200 2RS</b>	0.048
12	32	14	0.6	6240	1430	16000	<b>2201 2RS</b>	0.053
15	35	14	0.6	7410	1760	14000	<b>2202 2RS</b>	0.058
17	40	16	0.6	8840	2200	12000	<b>2203 2RS</b>	0.089
20	47	18	1.0	12700	3400	10000	<b>2204 2RS</b>	0.140
25	52	18	1.0	14300	4000	9000	<b>2205 2RS</b>	0.160
30	62	20	1.0	15600	4650	7500	<b>2206 2RS</b>	0.260
35	72	23	1.1	19000	6000	6300	<b>2207 2RS</b>	0.410
40	80	23	1.1	19900	6950	5600	<b>2208 2RS</b>	0.500
45	85	23	1.1	22900	7800	5300	<b>2209 2RS</b>	0.530
50	90	23	1.1	22900	8150	4800	<b>2210 2RS</b>	0.570
55	100	25	1.5	27600	10600	4300	<b>2211 2RS</b>	0.790
60	110	28	1.5	31200	12200	3800	<b>2212 2RS</b>	1.050

**BALL BEARING**  
**SERIES 23, 23..K**

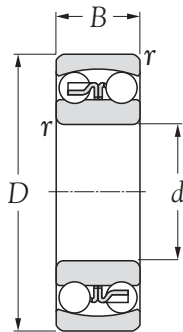

Cylindrical bore



Tapered bore  
taper 1:12

Boundary dimensions				Basic load ratings		Limiting speeds		Bearing numbers		Mass	
mm				dynamic	static	rpm				cylindrical bore	tapered bore
<i>d</i>	<i>D</i>	<i>B</i>	<i>r</i> <i>s min</i> <sup>1)</sup>	<i>C<sub>r</sub></i>	<i>C<sub>or</sub></i>	grease	oil			(approx.)	
10	35	17	0.6	10100	2150	17000	20000	<b>2300</b>	-	0.083	-
12	37	17	1.0	11800	2710	15000	17000	<b>2301</b>	-	0.091	-
15	42	17	1.0	12000	2900	13000	15000	<b>2302</b>	-	0.114	-
17	47	19	1.0	14400	3550	11000	14000	<b>2303</b>	-	0.156	-
20	52	21	1.1	18100	4700	10000	12000	<b>2304</b>	<b>2304K</b>	0.206	0.201
25	62	24	1.1	24400	6600	8500	10000	<b>2305</b>	<b>2305K</b>	0.334	0.326
30	72	27	1.1	31500	8750	7200	8500	<b>2306</b>	<b>2306K</b>	0.496	0.485
35	80	31	1.5	39500	11300	6300	7400	<b>2307</b>	<b>2307K</b>	0.671	0.653
40	90	33	1.5	45000	13500	5600	6600	<b>2308</b>	<b>2308K</b>	0.918	0.895
45	100	36	1.5	54000	16700	5000	5900	<b>2309</b>	<b>2309K</b>	1.230	1.200
50	110	40	2.0	64500	20200	4600	5400	<b>2310</b>	<b>2310K</b>	1.630	1.590
55	120	43	2.0	75500	24000	4200	4900	<b>2311</b>	<b>2311K</b>	2.100	2.050
60	130	46	2.1	87000	28200	3800	4500	<b>2312</b>	<b>2312K</b>	2.590	2.520

**BALL BEARING**  
**SERIES 23..2RS**

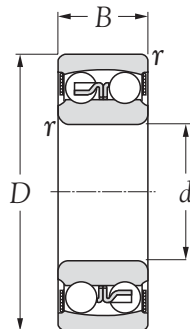

Boundary dimensions				Basic load ratings		Speed rating	Bearing numbers	Mass
mm				dynamic	static	rpm		kg
<i>d</i>	<i>D</i>	<i>B</i>	<i>r</i> s min <sup>1</sup>	<i>C<sub>r</sub></i>	<i>C<sub>0r</sub></i>	grease		(approx.)
15	42	17	1.0	10800	2600	12000	<b>2302 2RS</b>	0.11
17	47	19	1.0	12700	3400	11000	<b>2303 2RS</b>	0.16
20	52	21	1.1	14300	4000	9500	<b>2304 2RS</b>	0.21
25	62	24	1.1	19000	5400	7500	<b>2305 2RS</b>	0.34
30	72	27	1.1	22500	6800	6700	<b>2306 2RS</b>	0.51
35	80	31	1.5	26500	8500	5600	<b>2307 2RS</b>	0.70
40	90	33	1.5	33800	11200	5000	<b>2308 2RS</b>	0.96
45	100	36	1.5	39000	13400	4500	<b>2309 2RS</b>	1.30
50	110	40	2.0	43600	14000	4000	<b>2310 2RS</b>	1.65



**NOTE**

AUTOMATION TECHNOLOGY





## **NOTE**

AUTOMATION TECHNOLOGY

**NIPPON KODO AUTOMATION TECHNOLOGY CO. LTD.**

**[HTTP://WWW.NIPPONKODOBEARINGS.CO.JP](http://www.nipponkodobearings.co.jp)**

**HEADQUARTER:**

**ADDRESS: ROOM 205, GRANDEUR IMAZATO BLDG.**

**NO. 1-4, 4-CHOME, IMAZATO,**

**NAGAKAKYO-CITY 617-0814,**

**KYOTO, JAPAN**

**TEL: 81-75-959-0221**

**FAX: 81-75-959-0222**

**E-MAIL: [NIKO@NIPPONKODOJAPAN.COM](mailto:NIKO@NIPPONKODOJAPAN.COM)**

**CAT. NO. NIKO-BB 1/E-07**